

Our associates will ensure the tool works properly before you leave the store. If you experience issues with the tool while completing your project, simply bring it back to the Tool Rental Center to get a replacement. If you purchase Damage Protection at the time of your rental, you are not responsible for repair costs for tools that break due to normal use.





EN

Operation & Maintenance Manual

Mini Track Loader



MT100 S/N: B52P11001 & Above



OPERATOR SAFETY WARNINGS



- Never operate without instructions. See machine signs (decals), Operation & Maintenance Manual.
- Operator must have instructions before operating the machine. Untrained operators can cause injury or death.

SAFETY EQUIPMENT

The Bobcat machine must be equipped with safety items necessary for each job. Ask your Bobcat dealer for information on the availability and safe use of attachments and accessories.

- **SAFETY SIGNS (DECALS):** Replace if damaged.
- **LIFT ARM SUPPORT:** Replace if damaged.
- **PARKING BRAKE:** Check function, adjust or repair if necessary.
- **CONTINUOUS FLOW SHUTOFF PEDAL:** Check function, adjust or repair as necessary.



This check mark means: "Follow instructions for proper operations." Carefully read the message that follows.



- Never carry riders.
- Keep bystanders away from work area.



- Always carry bucket or attachment as low as possible.
- Do not travel or turn with lift arms up.
- Keep heavy end uphill.



- Never leave loader with engine running or with lift arms up.
- To park, engage parking brake, lower lift arms and put attachment flat on the ground.

OPERATOR SAFETY WARNINGS



This Safety Alert Symbol means: "Attention! Be Alert! Your Safety is Involved!" Carefully read the message that follows.



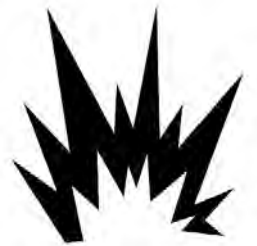
- Never drive over drop offs or jerk on the controls.



- Never modify equipment.
- Use only attachments approved by Bobcat Company for this model loader.



- Keep load level when raising lift arms to avoid spilling the load.
- Never exceed Rated Operated Capacity.
- Never leave operator position with load raised.



- Do not use loader in atmosphere with explosive dust, explosive gas, or where exhaust can contact flammable material.



FOREWORD	5
DECLARATION OF CONFORMITY	5
DECLARATION OF CONFORMITY	6
INTRODUCTION	7
Bobcat Company Is ISO 9001 Certified (ISO, BSI, and TUV only)	7
MANUFACTURER	7
North America	7
Czech Republic	7
SERIAL NUMBER LOCATIONS	8
Machine Serial Number	8
Engine Serial Number	8
DELIVERY REPORT	8
MACHINE IDENTIFICATION	9
FEATURES, ACCESSORIES, AND ATTACHMENTS	10
Standard Items	10
Options And Accessories	10
Attachments	10
Buckets Available.....	11
SAFETY AND TRAINING RESOURCES	12
BEFORE OPERATION	12
SAFE OPERATION IS THE OPERATOR’S RESPONSIBILITY	12
SAFE OPERATION NEEDS A QUALIFIED OPERATOR	13
A QUALIFIED OPERATOR MUST DO THE FOLLOWING	13
SILICA DUST EXPOSURE	14
FIRE PREVENTION	14
Maintenance	14
Operation	14
Electrical	14
Hydraulic System	14
Fuelling (Diesel).....	15
Starting	15
Spark Arrester Exhaust System.....	15
Welding And Grinding	15
Fire Extinguishers	15
PUBLICATIONS AND TRAINING RESOURCES	16
PICTORIAL ONLY SAFETY SIGNS	16
MACHINE SIGNS (DECALS)	17
OPERATING INSTRUCTIONS	26
INTENDED USE	26
CONTROL IDENTIFICATION	27
OPERATOR CONTROLS	27
Operator Controls Description.....	27
LIFT ARM BYPASS CONTROL	28
Operating Lift Arm Bypass Control	28
ENGINE SPEED CONTROL	28
Operating Engine Speed Control	28
PARKING BRAKE	29
Operating The Parking Brake.....	29
OPERATOR STATION	30
Operator Position Description	30
DRIVING AND STEERING THE MACHINE	30
Operating The Machine	30
STOPPING THE MACHINE	31

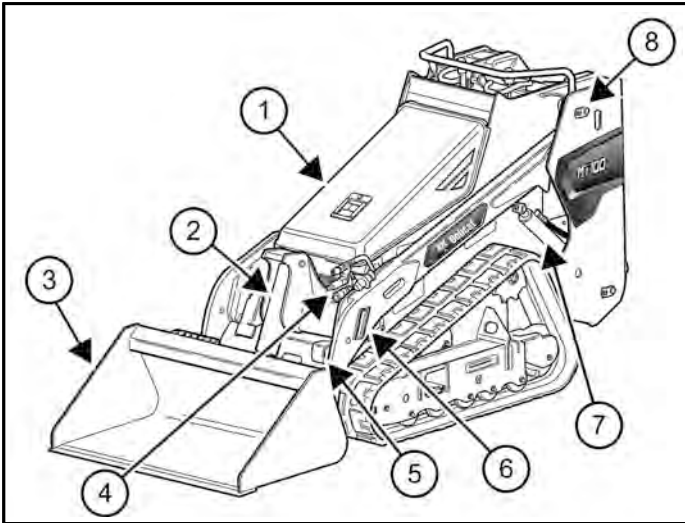
Using The Drive / Steering Control To Stop The Machine	31
HYDRAULIC CONTROLS	31
Lift / Tilt Joystick Description	31
Operating The Lift Arm Float Position	31
Auxiliary Hydraulic Control Variable Flow	32
Auxiliary Hydraulic Control Continuous Flow	32
Standard Auxiliary Quick Couplers	33
Relieve Hydraulic Pressure (Machine And Attachment)	33
ATTACHMENT CONTROL DEVICE (ACD)	34
Attachment Control Device (ACD) Description	34
DAILY INSPECTION	35
Daily Inspection And Maintenance	35
PRE-STARTING PROCEDURE	36
Pre-Starting Procedure	36
STARTING THE ENGINE	37
Starting Engine With Key Switch	37
Cold Temperature Starting	38
Warming The Hydraulic / Hydrostatic System	38
STOPPING THE ENGINE AND LEAVING THE MACHINE	39
Stopping The Engine And Leaving The Machine Procedure	39
COUNTERWEIGHTS	40
Counterweights Description	40
Effect On The Machine And Operations	40
When To Consider Track Frame Mounted Counterweights	40
When To Consider Main Frame Upright Mounted Counterweights	40
Counterweight Positions	40
ATTACHMENTS	41
Rated Operating Capacity Description	41
Choosing The Correct Attachment	41
Calculating The Rated Operating Capacity For Buckets	41
Pallet Fork	42
Installing The Attachment (Bob-Tach System)	42
Removing The Attachment (Bob-Tach System)	43
Installing The Attachment (Common Industry Interface)	44
Removing The Attachment (Common Industry Interface)	45
OPERATING PROCEDURE	46
Inspect The Work Area	46
Basic Operating Instructions	46
Operating Near An Edge Or Water	46
Driving On Rough Terrain And Over Kerbs	46
Driving With An Auger Attachment Installed	47
Operating With A Full Bucket	48
Operating With An Empty Bucket	48
TOWING THE MACHINE	49
Towing The Machine Procedure	49
LIFTING THE MACHINE	49
Four Point Lift	49
TRANSPORTING THE MACHINE	50
Loading And Unloading The Machine On A Trailer	50
Fastening The Machine	50
PREVENTIVE MAINTENANCE	52
MAINTENANCE SAFETY WARNINGS	52
MAINTENANCE SAFETY WARNINGS	53
SERVICE SCHEDULE	54
Maintenance Intervals	54
INSPECTION CHECKBOOK	58

LIFT ARM BYPASS CONTROL	58
Inspecting Lift Arm Bypass Control	58
LIFT AND TILT FUNCTION LOCKOUTS	59
Inspecting Lift And Tilt Function Lockouts	59
NEUTRAL START INTERLOCKS	60
Inspecting Traction Drive Interlock	60
Inspecting Auxiliary Hydraulic Interlock	60
AUXILIARY HYDRAULIC CONTROL SYSTEM	61
Inspecting The Continuous Flow Shutoff Pedal	61
LIFT ARM SUPPORT	62
Installing Lift Arm Support	62
Removing The Lift Arm Support	63
HOOD	63
Raising And Lowering The Hood	63
Striker Adjustment	64
REAR DOOR	64
Opening And Closing Rear Door	64
Rear Door Bumper Adjustment	65
AIR CLEANER SERVICE	65
Replacing The Filter Elements	65
Replacing The Outer Filter	65
Replacing The Inner Filter	66
FUEL SYSTEM	67
Fuel Specifications	67
Biodiesel Blend Fuel	67
Filling The Fuel Tank	67
Fuel Filter	68
Removing Air From The Fuel System	68
ENGINE LUBRICATION SYSTEM	70
Checking And Adding Engine Oil	70
Engine Oil Chart	70
Removing And Replacing Oil And Filter	70
ENGINE COOLING SYSTEM	72
Coolant Types	72
Cleaning Engine Cooling System	72
Checking Engine Coolant Level	72
Coolant Concentration	72
Removing The Coolant	73
Replacing The Coolant	74
ELECTRICAL SYSTEM	74
Electrical System Description	74
Fuse And Relay Location	74
Fuse And Relay Identification	74
Battery Maintenance	75
Maintaining Battery Charge Level	76
Battery Service During Machine Storage	76
Testing The Battery	76
Battery Charging	76
Using A Booster Battery (Jump Starting)	77
Removing And Installing The Battery	78
HYDRAULIC / HYDROSTATIC SYSTEM	79
Checking And Adding Hydraulic Fluid	79
Hydraulic Fluid Chart	79
Removing And Replacing Hydraulic / Hydrostatic Filter	79
Removing And Replacing Hydraulic Fluid	80
Hydraulic Reservoir Breather	80
SPARK ARRESTER MUFFLER	81

Cleaning Procedure.....	81
TRACK TENSION	82
Adjusting Track Tension.....	82
ALTERNATOR BELT	83
Alternator Belt Adjustment	83
Alternator Belt Replacement.....	83
DRIVE BELT	84
Drive Belt Description	84
Drive Belt Adjustment	84
TRACK ROLLER AND IDLER LUBRICATION	85
Track Roller And Idler Lubrication Description	85
MACHINE LUBRICATION	86
Lubricating Grease Fittings	86
Parking Brake Lubrication	87
PIVOT PINS	87
Inspecting And Maintaining Pivot Pins	87
BOB-TACH SYSTEM (HAND LEVER)	88
Inspecting And Maintaining The Bob-Tach System	88
COMMON INDUSTRY INTERFACE	89
Inspecting And Maintaining Common Industry Interface	89
MACHINE STORAGE AND RETURN TO SERVICE	91
Machine Extended Storage Procedure	91
Machine Return To Service Procedure.....	91
SPECIFICATIONS	92
DIMENSIONS (NARROW TRACK)	92
DIMENSIONS (WIDE TRACK)	94
PERFORMANCE	96
CONTROLS	97
SPECIFICATION BUCKET SPECIFICATIONS	98
ENGINE	99
HYDRAULIC SYSTEM	100
ELECTRICAL	101
DRIVE SYSTEM	102
CAPACITIES	103
TRACKS	104
GROUND PRESSURE	105
ENVIRONMENTAL SPECIFICATIONS	106
TEMPERATURE RANGE	107
TORQUE SPECIFICATION FOR BOLTS	108
Torque For General SAE Bolts	108
Torque For General Metric Bolts	108
WARRANTY	110
MACHINE WARRANTY	110

MACHINE IDENTIFICATION

Figure 4

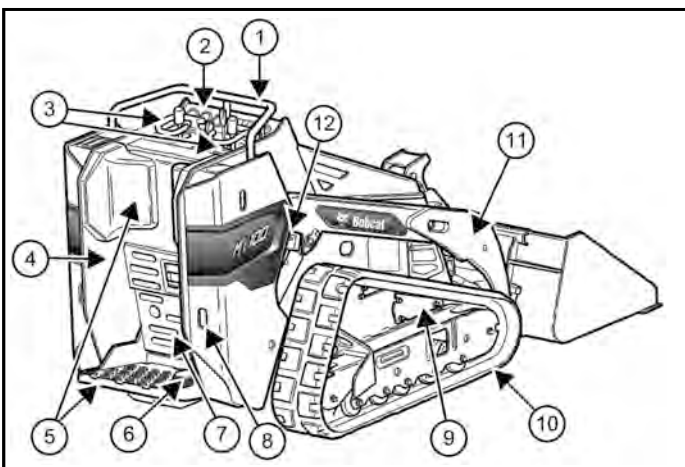


NA18545a

REF.	DESCRIPTION
1	Hood
2	Tilt Cylinder
3	Bucket [A]
4	Auxiliary Hydraulic Quick Couplers
5	Lift Point / Tie-Down
6	Tie-Down
7	Lift Cylinder
8	Lift Point

[A] Buckets - Several different buckets and other attachments are available for the Bobcat machine.

Figure 5



NA18545a

REF.	Description
1	Grab Bar
2	Instrument Panel
3	Controls
4	Operation & Maintenance Manual (Inside Rear Door)
5	Operator Position
6	Continuous Flow Shutoff Pedal
7	Rear Door
8	Tie-Down
9	Counterweight
10	Tracks [A]
11	Lift Arms
12	Lift Arm Support Storage Position

[A] Tracks - Optional tracks are available.

FEATURES, ACCESSORIES, AND ATTACHMENTS

Standard Items

Specifications subject to change without notice and standard items may vary.

Model MT100 Bobcat Machines are equipped with the following standard items:

- Auxiliary Hydraulics, Front
- Instrumentation: Hourmeter, Engine Temperature, Voltmeter and Fuel Gauges, Warning Lights
- Lift and Tilt Control Joystick
- Lift Arm Support
- Multifunction Drive Control Joystick
- Parking Brake
- Spark Arrester Muffler
- Operator Position
- Storage Compartment
- Cup Holder

Options And Accessories

Below is a list of equipment available for your Bobcat Machine as Dealer or Factory Installed Accessories and Factory Installed Options. See your Bobcat dealer for other available options, accessories, and attachments.

- Attachment Control Kit
- Case Drain Kit
- ~~Engine Block Heater~~
- Engine Protection Shutdown Kit
- ~~Exhaust Purifier~~
- Operating Light Kit
- Bob-Tach®
- Common Industry Interface
- Rubber Tracks – 250 mm (9.8 in)
- Rubber Tracks – 180 mm (7 in)

Attachments

WARNING

MODIFICATION HAZARD

Unapproved attachments can cause serious injury or death.

Never use attachments or buckets that are not approved by Bobcat Company. Attachments and buckets for safe loads of specified densities are approved for each model. Read and understand the load capacity information for the attachment you are using.

W-2392

These and other attachments are approved for use on this model machine. Do not use unapproved attachments. Attachments not manufactured by Bobcat may not be approved.

The versatile Bobcat Machine quickly turns into a multi-job machine with available Bob-Tach / Common Industry Interface attachment couplers, and a wide variety of approved attachments.

See your Bobcat dealer for more details on these and other attachments and field accessories.

NOTE: Warranty is void if non-approved attachments are used on the Bobcat machine.

Bob-Tach System Compatible Attachments

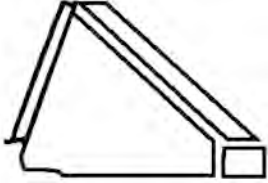
- Adapter Interface
- Angle Broom
- Auger
- Boring, Mini
- Breaker
- Brushcat
- Buckets
- Grapple, General Purpose
- Grapple, Industrial
- Grapple, Root
- Grapple, Utility
- Landplane
- Log Grapple
- Pallet Fork
- Scraper
- Snow Blower
- Soil Conditioner
- Sweeper
- Stump Grinder
- Tiller
- Trencher
- Utility Blade

Common Industry Interface Compatible Attachments

- Auger

- Breaker
- Buckets
- Pallet Fork
- Trencher

Buckets Available



Many bucket styles, widths and different capacities are available for a variety of different applications. They include Construction and Industry, Utility and General Purpose, to name a few. See your Bobcat dealer for the correct bucket for your Bobcat machine and application.

BEFORE OPERATION

WARNING

INSUFFICIENT INSTRUCTIONS HAZARD

Untrained operators or failure to follow instructions can cause serious injury or death. Operators must have adequate training and instruction before operating. ◀

W-2001

Carefully follow the operating and maintenance instructions in this manual.

The Bobcat machine is highly manoeuvrable and compact. It is rugged and useful under a wide variety of conditions. This presents an operator with hazards associated with off motorway, This presents an operator with hazards associated with off motorway, rough terrain applications, common with Bobcat machine usage.

The Bobcat machine has an internal combustion engine with resultant heat and exhaust. All exhaust gases can kill or cause illness so use the machine with adequate ventilation.

The dealer explains the capabilities and restrictions of the Bobcat machine and attachment for each application. The dealer demonstrates the safe operation according to Bobcat instructional materials, which are also available to operators. The dealer can also identify unsafe modifications or use of unapproved attachments. The attachments and buckets are designed for a specific Rated Operating Capacity (ROC) (some have restricted lift heights). They are designed for secure fastening to the machine. The user must check with the dealer, or Bobcat literature, to determine safe loads of materials of specified densities for the machine - attachment combination.

The following publications and training materials provide information on the safe use and maintenance of the Bobcat machine and attachments:

- The Delivery Report is used to assure that complete instructions have been given to the new owner and that the machine and attachment are in safe operating condition.
- The Operation & Maintenance Manual delivered with the machine or attachment gives operating information as well as routine maintenance and service procedures. It is a part of the machine and can be stored in a container provided on the machine. Replacement Operation & Maintenance Manuals can be ordered from your Bobcat dealer.
- Machine signs (decals) instruct on the safe operation and care of your Bobcat machine or attachment. The signs and their locations are shown in the Operation & Maintenance Manual. Replacement signs are available from your Bobcat dealer.

The dealer and owner / operator review the recommended uses of the product when delivered. If the owner / operator will be using the machine for a different application(s) he or she must ask the dealer for recommendations on the new use.

SAFE OPERATION IS THE OPERATOR'S RESPONSIBILITY



Safety Alert Symbol

This symbol with a warning statement means: "Warning, be alert! Your safety is involved!" Carefully read the message that follows.

DANGER

The signal word DANGER on machine signs and in the manuals indicates a hazardous situation which, if not avoided, will result in serious injury or death. ◀

D-1002

WARNING

The signal word WARNING on the machine and in the manuals indicates a potentially hazardous situation which, if not avoided, could result in serious injury or death. ◀

W-2044

IMPORTANT

The signal word IMPORTANT in the manuals indicates a potentially hazardous situation which, if not avoided, could result in damage to the machine. ◀

I-2019

Bobcat Company cannot anticipate every possible use that might involve a potential hazard. The warnings in this publication and on the product are, therefore, not all-inclusive. If you have questions about your specific application, please see your Bobcat dealer or Bobcat customer service.

The machine and attachment must be in good operating condition before use.

Check all of the items on the Service Schedule decal (if equipped) in the Every 8 Hours section or as shown in the Operation & Maintenance Manual.

SAFE OPERATION NEEDS A QUALIFIED OPERATOR

For an operator to be qualified, he or she must not use drugs or alcoholic drinks which impair alertness or coordination while working. An operator who is taking prescription drugs must get medical advice to determine if he or she can safely operate a machine.

A QUALIFIED OPERATOR MUST DO THE FOLLOWING

- Understand the written instructions, rules, and regulations.
 - ▷ Check the rules and regulations at your location. The rules may include an employer's work safety requirements. Regulations may apply to local driving requirements or use of a Slow Moving Vehicle (SMV) emblem. Regulations may identify a hazard such as a utility line.
- Have training with actual operation.
 - ▷ Operator training must consist of a demonstration and verbal instruction. This training is given by your Bobcat dealer before the product is delivered.
 - ▷ The new operator must start in an area without bystanders and use all the controls until he or she can operate the machine and attachment safely under all conditions of the work area.
 - ▷ Operator Training Courses are available from your Bobcat dealer in English and Spanish. They provide information for safe and efficient equipment operation. Safety videos are also available.
- Know the work conditions.
 - ▷ Know the weight of the materials being handled. Avoid exceeding the ROC Material that is very dense will be heavier than the same volume of less dense material. Reduce the size of load if handling dense material.
 - ▷ The operator must know any prohibited uses or work areas, for example, he or she needs to know about excessive slopes.
 - ▷ Know the location of any underground lines. Call local utilities or the toll-free phone number found in the Before Operation section of this manual.
 - ▷ Wear tight fitting clothing. Always wear safety glasses when doing maintenance or service. Safety glasses, respiratory equipment, hearing protection or Special Applications Kits are required for some work. See your Bobcat dealer about Bobcat safety equipment for your model.

SILICA DUST EXPOSURE



Cutting or drilling concrete containing sand or rock containing quartz may result in exposure to silica dust. Use a respirator, water spray, or other means to control dust.

FIRE PREVENTION



Maintenance

The machine and some attachments have components that are at high temperatures under normal operating conditions. The primary source of high temperatures is the engine and exhaust system. The electrical system, if damaged or incorrectly maintained, can be a source of arcs or sparks.

Flammable debris (leaves, straw, etc.) must be removed regularly. If flammable debris is allowed to accumulate, it can cause a fire hazard. Clean often to avoid this accumulation. Flammable debris in the engine compartment is a potential fire hazard.

The operator's area, engine compartment, and engine cooling system must be inspected every day and cleaned if necessary to prevent fire hazards and overheating.

All fuels, most lubricants, and some coolant mixtures are flammable. Flammable fluids that are leaking or spilled onto hot surfaces or onto electrical components can cause a fire.

Operation

Do not use the machine where exhaust, arcs, sparks, or hot components can contact flammable material, explosive dust, or gases.

Electrical



Check all electrical wiring and connections for damage. Keep the battery terminals clean and tight. Repair or replace any damaged part or wires that are loose or frayed.

Battery gas can explode and cause serious injury. Use the procedure in the Operation & Maintenance Manual for connecting the battery and for jump starting. Do not jump start or charge a frozen or damaged battery. Keep any open flames or sparks away from batteries. Do not smoke in battery charging area.

Hydraulic System

Check hydraulic tubes, hoses, and fittings for damage and leakage. Never use open flame or bare skin to check for leaks. Hydraulic tubes and hoses must be properly routed and have adequate support and secure clamps. Tighten or replace any parts that show leakage.

Always clean fluid spills. Do not use petrol or diesel fuel for cleaning parts. Use commercial non-flammable solvents.

Fuelling (Diesel)



C229537

Stop the engine and let it cool before adding fuel. No smoking! Do not refuel a machine near open flames or sparks. Fill the fuel tank outdoors.

Ultra Low Sulfur Diesel (ULSD) poses a greater static ignition hazard than earlier diesel formulations with higher sulfur content. Avoid death or serious injury from fire or explosion. Consult with your fuel or fuel system supplier to ensure the delivery system is in compliance with fuelling standards for proper earthing and bonding practices.

Starting

Do not use ether or starting fluids on any engine that has glow plugs or an air intake heater. These starting aids can cause explosion and injure you or bystanders.

Use the procedure in the Operation & Maintenance Manual for connecting the battery and for jump starting.

Spark Arrester Exhaust System

The spark arrester exhaust system is designed to control the emission of hot particles from the engine and exhaust system, but the muffler and the exhaust gases are still hot.

Check the spark arrester exhaust system regularly to make sure it is maintained and working properly. Use the procedure in the Operation & Maintenance Manual for cleaning the spark arrester muffler (if equipped).

Welding And Grinding

Always clean the machine and attachment, disconnect the battery, and disconnect the wiring from the Bobcat controllers before welding. Cover rubber hoses, battery, and all other flammable parts. Keep a fire extinguisher near the machine when welding.

Have adequate ventilation when grinding or welding painted parts. Wear a dust mask when grinding painted parts. Toxic dust or gas can be produced.

Dust generated from repairing non-metallic parts such as hoods, fenders, or covers can be flammable or explosive. Repair such components in a well-ventilated area away from open flames or sparks.

Fire Extinguishers

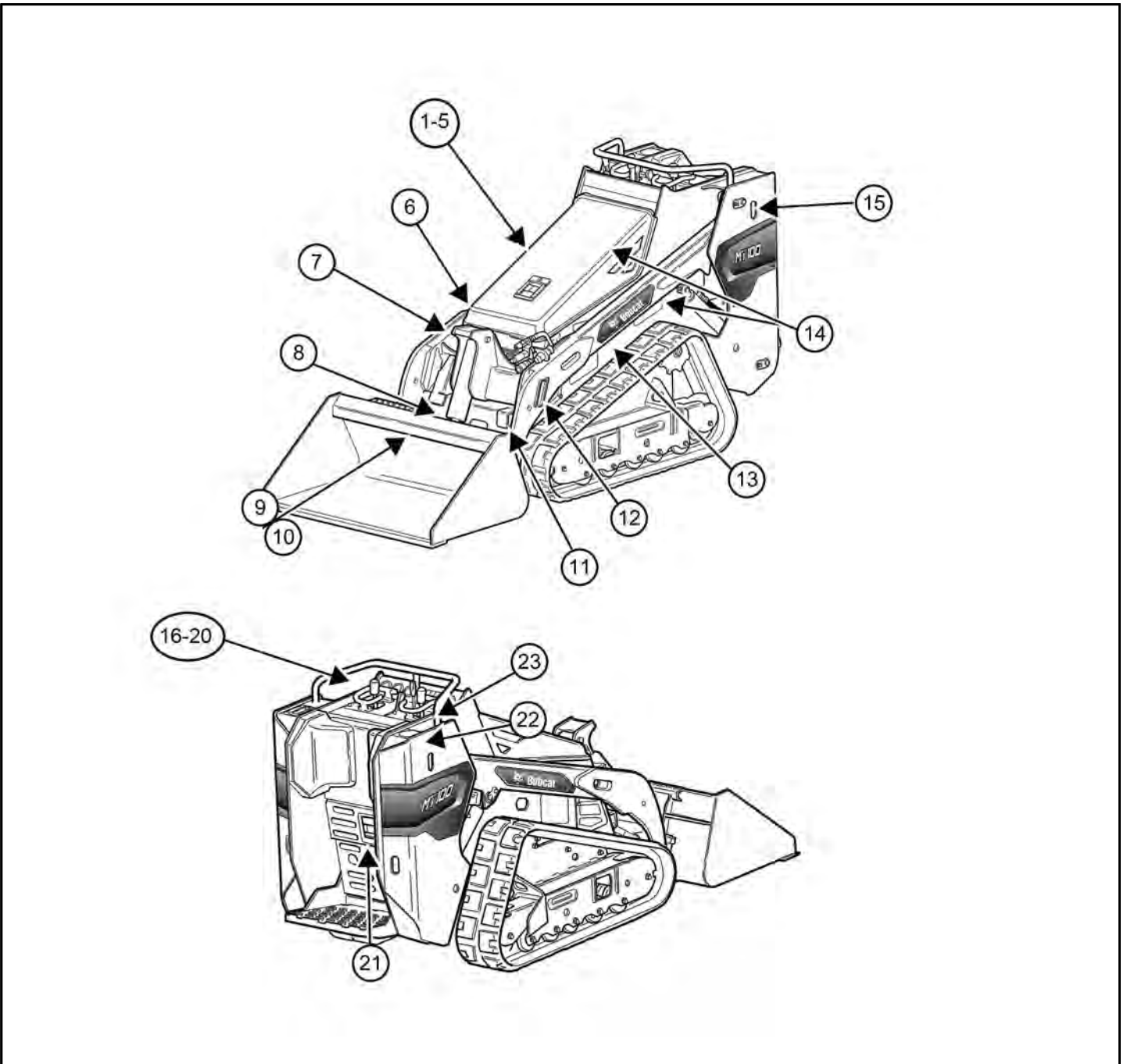


P200083

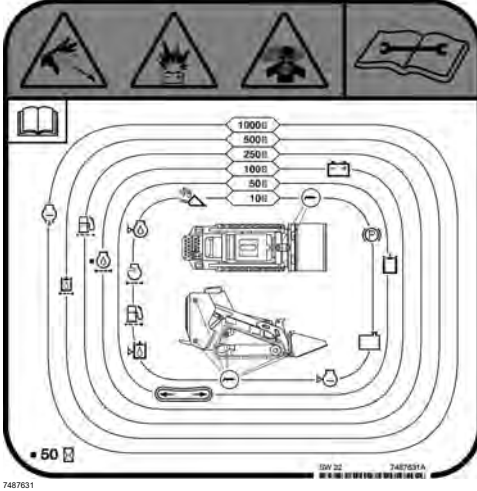

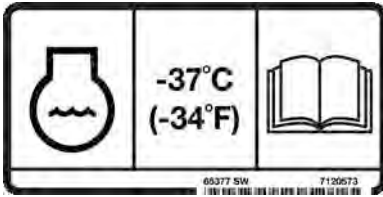
Know where fire extinguishers and first aid kits are located and how to use them. Inspect the fire extinguisher regularly. Service or replace as needed. Obey the recommendations on the instructions plate.


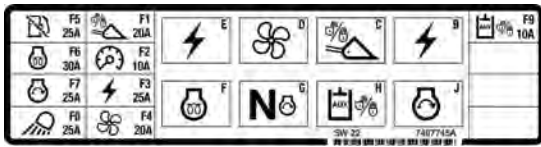
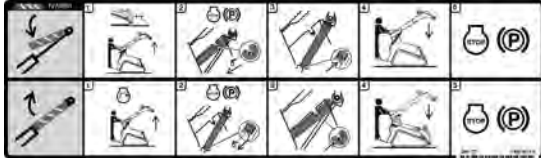
MACHINE SIGNS (DECALS)





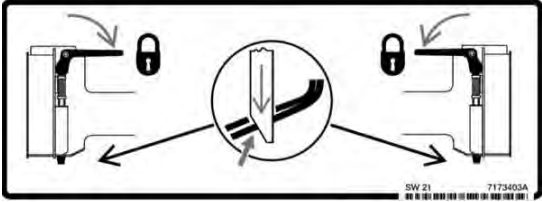

Figure 7

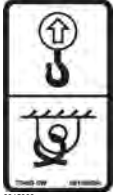









C200206

REF.	DECAL	Warning or Instruction (If applicable)
1	<p data-bbox="225 237 432 264">Service Schedule</p> <p data-bbox="225 293 328 320">7487631</p> <p data-bbox="225 344 655 371">This decal is located under the hood.</p>  <p data-bbox="225 875 256 887">7487631</p>	<div data-bbox="794 271 1481 331" style="background-color: black; color: white; text-align: center; padding: 5px;"> WARNING </div> <p data-bbox="794 338 1046 365">GENERAL HAZARD</p> <p data-bbox="794 367 1481 421">Failure to follow instructions can cause serious injury or death.</p> <ul data-bbox="794 423 1481 1066" style="list-style-type: none"> • Keep door / cover closed except for service. • Keep engine clean of flammable material. • Keep body, loose objects, and clothing away from electrical contacts, moving parts, hot parts, and exhaust. • Do not use the machine in space with explosive dusts or gases or with flammable material near exhaust. • Never use ether or starting fluid on diesel engine with glow plugs or air intake heater. Use only starting aids as approved by engine manufacturer. • Leaking fluids under pressure can enter skin and cause serious injury. • Battery acid causes severe burns; wear goggles. If acid contacts eyes, skin, or clothing, flush with water. For contact with eyes, flush and get medical attention. • Battery makes flammable and explosive gas. Keep arcs, sparks, flames, and lighted tobacco away. • For jump start, connect negative cable to the machine engine last (never at the battery). After jump start, remove negative connection at the engine first. • Exhaust gases can kill. Always ventilate. ◀ <p data-bbox="794 1055 826 1066">W-2782</p>
2	<p data-bbox="225 1115 480 1142">Hot Pressurized Fluid</p> <p data-bbox="225 1167 360 1193">7325124_A</p> <p data-bbox="225 1218 655 1245">This decal is located under the hood.</p>  <p data-bbox="225 1559 256 1570">7325124</p>	<div data-bbox="794 1144 1481 1205" style="background-color: black; color: white; text-align: center; padding: 5px;"> WARNING </div> <p data-bbox="794 1211 991 1238">BURN HAZARD</p> <p data-bbox="794 1240 1222 1267">Hot fluid can cause serious burns</p> <ul data-bbox="794 1270 1262 1335" style="list-style-type: none"> • Never open hot. • Open slowly to release pressure. ◀ <p data-bbox="794 1323 826 1335">W-2795</p>
3	<p data-bbox="225 1592 416 1619">Coolant System</p> <p data-bbox="225 1644 360 1671">7120573_0</p> <p data-bbox="225 1695 655 1722">This decal is located under the hood.</p>  <p data-bbox="225 1928 256 1939">7120573</p>	

REF.	DECAL	Warning or Instruction (If applicable)
4	<p>Hydrostatic Fluid</p> <p>7120570</p> <p>This decal is located under the hood.</p> 	
5	<p>Fuse Identification</p> <p>7487745</p> <p>This decal is located under the hood, inside the fuse cover.</p> 	
6	<p>Lift Arm Support</p> <p>7487627</p> <p>This decal is located behind the lift arm.</p> 	<p>To install approved lift arm support:</p> <ol style="list-style-type: none"> 1. Remove attachment from loader and raise the lift arms. 2. Stop the engine, engage the parking brake, and remove the pin. 3. Insert the pin to secure the lift arm support onto the cylinder rod. 4. Lower the lift arms slowly until lift arm support is held securely between lift arm and cylinder. 5. Stop the engine and engage the parking brake. <p>To remove lift arm support:</p> <ol style="list-style-type: none"> 1. Start the engine and raise the lift arms. 2. Stop the engine, engage the parking brake, and remove the pin. 3. Return the lift arm support to the storage position and secure with the pin. 4. Fully lower the lift arms. 5. Stop the engine and engage the parking brake.

REF.	DECAL	Warning or Instruction (If applicable)
7	<p>Tipping Hazard</p> <p>7487625</p> <p>This decal is located behind the crossbar.</p>  <p>7487625</p>	<div style="background-color: black; color: white; padding: 5px; text-align: center;">  WARNING </div> <p>INSTABILITY HAZARD Machine tipping or rollover can cause serious injury or death.</p> <ul style="list-style-type: none"> • Do not overload the machine. • Keep the lift arms as low as possible. • Do not travel or turn with the lift arms up. • Turn on level ground. Slow down when turning. • Go up and down slopes, not across them. • Keep the heavy end of the machine uphill. • Check for adequate traction. ◀ <p>W-2018</p>
8	<p>Crushing Hazard</p> <p>7487624</p> <p>This decal is located on the frame.</p>  <p>7487624</p>	<div style="background-color: black; color: white; padding: 5px; text-align: center;">  DANGER </div> <p>CRUSHING HAZARD Failure to follow instructions will cause serious injury or death.</p> <ul style="list-style-type: none"> • Disconnecting hydraulic lines can cause the lift arms or attachment to drop. • Always use an approved lift arm support when lift arms are in a raised position. ◀ <p>D-1008</p>
9	<p>Bob-Tach (if equipped)</p> <p>7173403</p> <p>This decal is located behind the Bob-Tach .</p>  <p>SW 21 7173403A</p>	
10	<p>Common Industry Interface (if equipped)</p> <p>7487622</p> <p>This decal is located behind the Common Industry Interface.</p>  <p>SW 22 7487622A</p>	

REF.	DECAL	Warning or Instruction (If applicable)
11	<p>Lift Point / Tie-Down</p> <p>6815993 (2)</p> <p>This decal is located on front of the machine.</p>  <p>6815993</p>	
12	<p>Tie-Down</p> <p>6595014 (4)</p> <p>This decal is located on the lift arms.</p>  <p>6595014</p>	
13	<p>Hot Surface</p> <p>7185935 (2)</p> <p>This decal is located under the hood and on the side of machine.</p>  <p>7185935</p> <p>70461 SW 7185935</p>	<p style="text-align: center;">! WARNING</p> <p>FIRE AND EXPLOSION HAZARDS Engines can have hot parts and hot exhaust gas that can cause serious injury or death.</p> <ul style="list-style-type: none"> • Keep flammable material away. • DO NOT use machines in an atmosphere containing explosive dust or gases. ◀ <p><small>W-2051</small></p>
14	<p>Rotating Parts</p> <p>7234367 (4)</p> <p>This decal is located under the hood and on the side.</p>  <p>7234367</p> <p>85398 SW 7234367</p>	<p style="text-align: center;">! WARNING</p> <p>ENTANGLEMENT AND BURN HAZARDS Contact with moving or hot parts can cause serious injury or death. Keep the engine cover closed when operating the machine. ◀</p> <p><small>W-2409</small></p>

REF.	DECAL	Warning or Instruction (If applicable)
17b	 <p>7452090b</p>	<p style="text-align: center;">! WARNING</p> <p>INSUFFICIENT INSTRUCTIONS HAZARD Untrained operators or failure to follow instructions can cause serious injury or death. Operators must have adequate training and instruction before operating. ◀</p> <p><small>W-2001</small></p>
17c	 <p>7452090c</p>	<p style="text-align: center;">! WARNING</p> <p>INSTABILITY HAZARD Machine tipping or rollover can cause serious injury or death.</p> <ul style="list-style-type: none"> • Do not overload the machine. • Keep the lift arms as low as possible. • Do not travel or turn with the lift arms up. • Turn on level ground. Slow down when turning. • Go up and down slopes, not across them. • Keep the heavy end of the machine uphill. • Check for adequate traction. ◀ <p><small>W-2018</small></p>
17d	 <p>7452090d</p>	<p style="text-align: center;">! WARNING</p> <p>GENERAL HAZARD Failure to follow instructions can cause serious injury or death.</p> <p>When using the ride-on platform:</p> <ul style="list-style-type: none"> • Operate only with feet on platform and hand on controls or grab handles. • Always look in the direction of travel. • Make sure swing area is clear of bystanders and objects. • Avoid drop-offs and obstacles. ◀ <p><small>W-2480</small></p>
17e	 <p>7452090e</p>	<p style="text-align: center;">! WARNING</p> <p>INSTABILITY HAZARD Failure to follow instructions can cause serious injury or death.</p> <ul style="list-style-type: none"> • Only operate from the operator position with feet on the platform and hands on the controls. • Always carry the load low. ◀ <p><small>W-3310</small></p>

REF.	DECAL	Warning or Instruction (If applicable)
------	-------	--

17f



⚠ WARNING

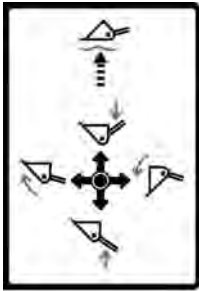
UNINTENDED MOVEMENT HAZARD
 Failure to follow instructions can cause serious injury or death.

Before leaving the machine:

- Fully lower the lift arm and put the attachment flat on the ground.
- Disengage auxiliary hydraulics.
- Reduce engine speed.
- Engage the parking brake.
- Stop the engine and remove the key. ◀

W-3311

17g



(See Hydraulic Controls on Page 31)

18 Engine Speed Control

6735140

This decal is located on the Control and Instrument Panel.








19 Engine Start

7487629

This decal is located on the Control and Instrument Panel.



REF.	DECAL	Warning or Instruction (If applicable)
20	<p>Parking Brake</p> <p>7487628</p> <p>This decal is located on the parking brake lever.</p>  <p>7487628</p>	
21	<p>Operation & Maintenance Manual Location</p> <p>6732148</p> <p>This decal is located on the rear door.</p>  <p>6732148</p>	<div style="background-color: black; color: white; padding: 5px; text-align: center;">  WARNING </div> <p>INSUFFICIENT INSTRUCTIONS HAZARD Untrained operators or failure to follow instructions can cause serious injury or death. Operators must have adequate training and instruction before operating. *</p> <p><small>W-2001</small></p>
22	<p>Tie-Down</p> <p>6595014 (4)</p> <p>This decal is located on the upright.</p>  <p>6595014</p>	
23	<p>Rated Operating Capacity</p> <p>7398440</p> <p>This decal is located on the right-hand side of the console.</p>  <p>7398440</p>	<p>(See Performance on Page 96)</p>

INTENDED USE

This machine is classified as a compact tool carrier otherwise known as a mini loader as defined in ISO 6165. This machine has tracks and commonly a front mounted bucket for the principle intended functions of digging, moving, levelling, lifting, carrying, and loading loose materials such as earth, gravel, or crushed rock.

Additional Bobcat approved attachments allow this machine to perform other tasks described in the attachment Operation & Maintenance Manuals. Bobcat cannot anticipate every possible use that might involve a potential hazard. The warnings in this publication and on the product are, therefore, not all-inclusive. If you have questions about your specific application please see your Bobcat dealer or Bobcat customer service.

WARNING



INSUFFICIENT INSTRUCTION HAZARD

Failure to follow instructions can cause serious injury or death.


- Read and understand the Operation & Maintenance Manual, Operator's Handbook, and decals on the machine and attachment.
- Always refer to reliable sources such as the Operation & Maintenance Manual, Operator's Handbook, Service Manual, and trainings and videos available from Bobcat Company. ◀

W-3312

Examples of intended use include:

Digging	
Backfilling	

Leveling	
----------	---

Piling Materials	
------------------	---

Loading Materials	
-------------------	--

Moving Palletized Materials	
-----------------------------	---

WARNING

INSTABILITY HAZARD

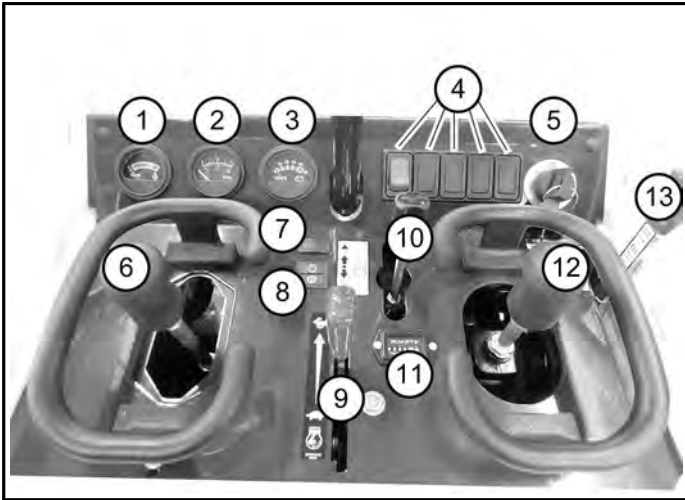
Machine tipping or rollover can cause serious injury or death.

Load, unload and turn on flat level ground. DO NOT exceed ROC. ◀

W-3195

CONTROL IDENTIFICATION

Figure 8



Reference numbers below refer to the components on the operator's console [Figure 8].

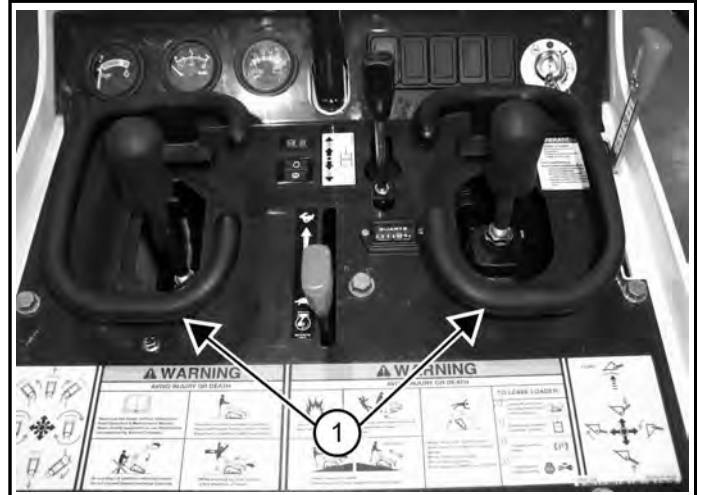
REF.	DESCRIPTION
1	Temperature Gauge
2	Fuel Gauge
3	Voltmeter
4	<ul style="list-style-type: none"> Lift Arm Bypass Attachment Control (Option) Attachment Control (Option) Lights (Option) Not Used
5	Key Switch
6	Drive / Steering Control Joystick
7	Shutdown Indicator (Option)
8	Engine Oil Pressure Warning Light / Hydraulic Temperature Warning Light
9	Engine Speed Control Lever
10	Auxiliary Hydraulic Control Lever
11	Hourmeter
12	Lift / Tilt Control Joystick
13	Parking Brake Lever

OPERATOR CONTROLS

Operator Controls Description

The operator controls control the drive / steering and lift / tilt functions. Move the controls smoothly to avoid sudden starting and stopping.

Figure 9



p124070a

Always use the Reference Bars (Item 1) [Figure 9] when operating the Drive / Steering Control Joystick and Lift / Tilt Control Joystick.

You can maintain better control of the functions when you use the Reference Bars to operate the Drive / Steering Control Joystick and Lift / Tilt Control Joystick.

⚠ WARNING

GENERAL HAZARD

Failure to follow instructions can cause serious injury or death.

When operating the machine:

- Operate only from the operator position at the rear of the loader.
- Always keep your hands on the controls.
- Stay away from the tracks. ◀

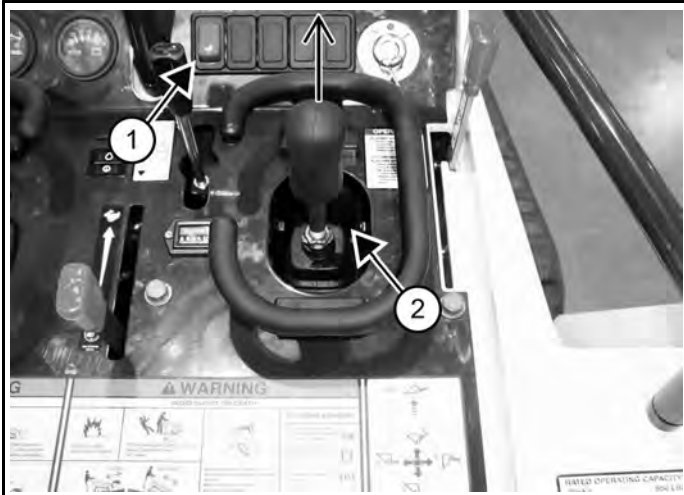
W-2407

LIFT ARM BYPASS CONTROL

Operating Lift Arm Bypass Control

The lift arm bypass switch is used to lower the lift arms when the engine is not running.

Figure 10

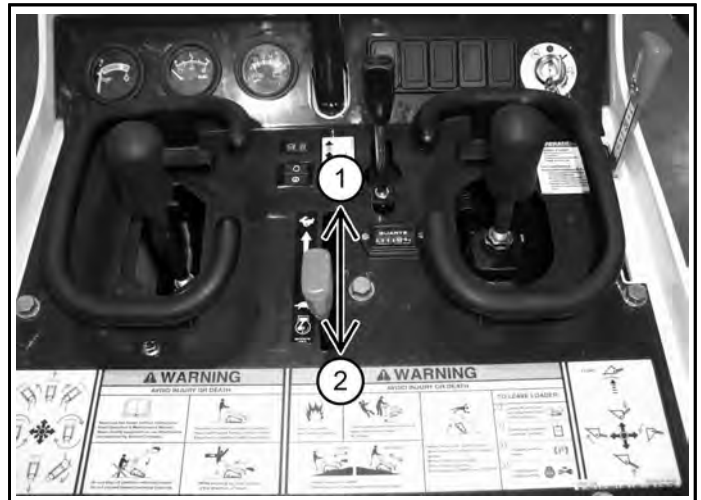


1. Press and hold the lift arm bypass switch (Item 1) [Figure 10].
2. Move the Lift / Tilt Control Joystick (Item 2) [Figure 10] forward to lower the lift arms.

ENGINE SPEED CONTROL

Operating Engine Speed Control

Figure 11



1. Move the engine speed control lever up (Item 1) [Figure 11] to increase engine speed.
2. Move the lever down (Item 2) [Figure 11] to decrease engine speed.

For maximum performance, run the engine at full speed while working.

PARKING BRAKE

Operating The Parking Brake

Engage the parking brake whenever you stop the machine.

To Engage:

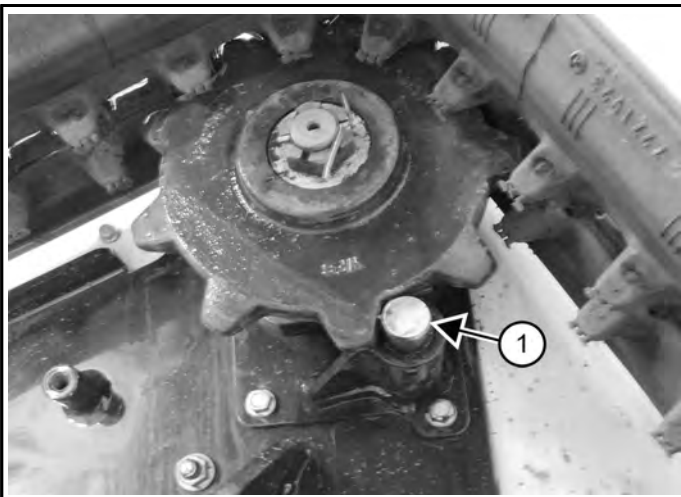
Figure 12



p124074a

1. Move the parking brake lever slightly forward, to the left and then FULLY backward to engage the parking brake (Item 1) [Figure 12].

Figure 13

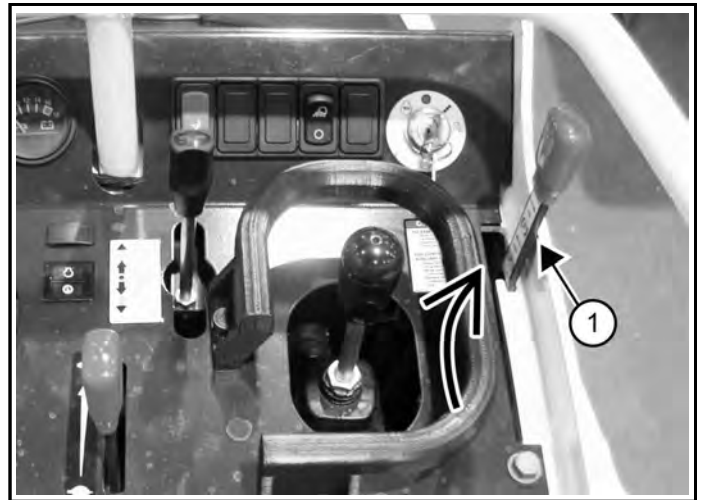


c201719a

2. Move the machine forward or backward slightly to ensure both parking brake pins (Item 1) [Figure 13] are engaged (between the teeth of the track drive sprockets), or to remove load pins when disengaging the parking brake.

To Release:

Figure 14



p118992c

3. Move the parking brake lever forward, to the right and then slightly backward (Item 1) [Figure 14] until the lever is inserted into the slot to release the parking brake.

OPERATOR STATION

Operator Position Description

⚠ WARNING

GENERAL HAZARD

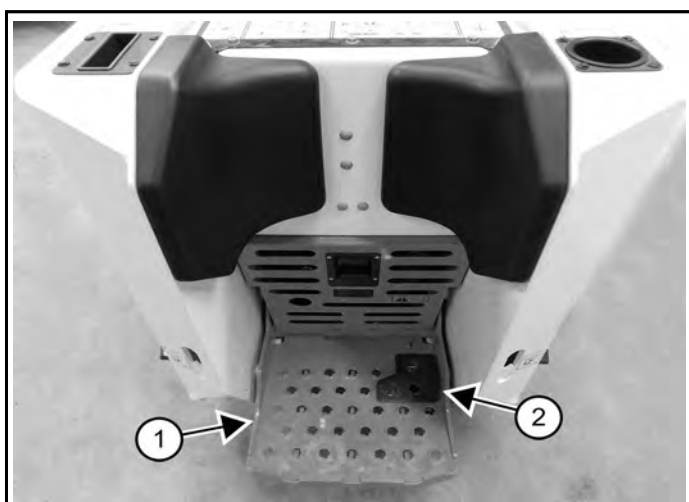
Failure to follow instructions can cause serious injury or death.

When operating the machine:

- Operate only from the operator position at the rear of the loader.
- Always keep your hands on the controls.
- Stay away from the tracks. ◀

W-2407

Figure 15



A cushioned operator position and operator position (Item 1) [Figure 15] are integrated in the rear of the machine. The operator position provides a stable area for the operator to stand while operating the machine.

Never operate the machine from the ground. Always keep your hands on the controls and feet on the platform while operating the machine.

The Continuous Flow Shutoff Pedal (Item 2) is located on the operator position and is activated when the pedal is pressed by the operator. The Continuous Flow Shutoff Pedal (Item 2) [Figure 15] allows the Continuous Auxiliary Hydraulic Flow Function to be used.

- When the operator occupies the Operator Platform and depresses the pedal, the Continuous Auxiliary Hydraulic Flow Function is enabled.
- When the operator releases the pedal, the Continuous Auxiliary Hydraulic Flow Function is disabled.

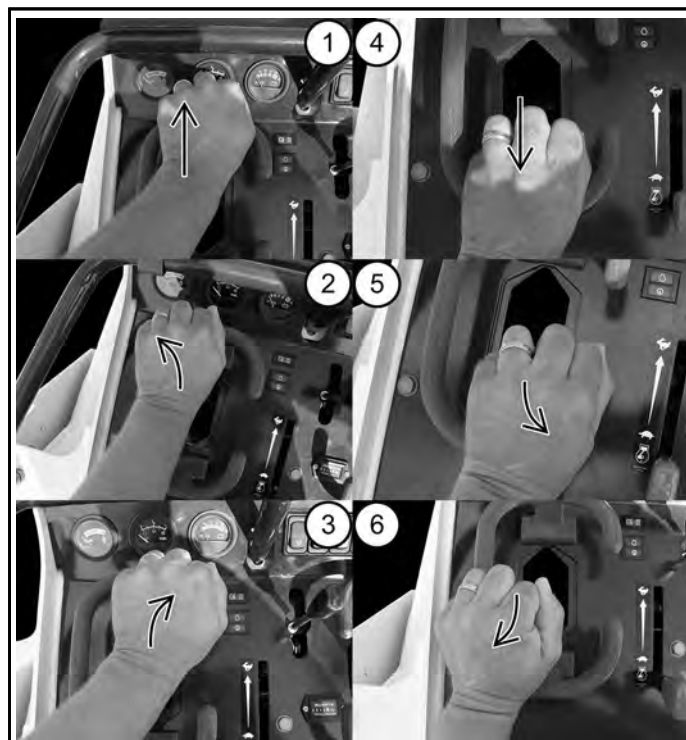
DRIVING AND STEERING THE MACHINE

Operating The Machine

The engine will not start unless the Drive / Steering Control Joystick is in Neutral.

The Drive / Steering Control Joystick is on the left side of the operator's console. Operate the Drive / Steering Control Joystick to function as follows:

Figure 16



- To travel forward move the Drive / Steering Control Joystick forward (Item 1) [Figure 16].
- To make a left hand turn while moving forward move the Drive / Steering Control Joystick forward and to the left (Item 2) [Figure 16].
- To make a right hand turn while moving forward move the Drive / Steering Control Joystick forward and to the right (Item 3) [Figure 16].
- To travel in reverse move the Drive / Steering Control Joystick backward (Item 4) [Figure 16].
- To make a left turn while going reverse move the Drive / Steering Control Joystick backward and to the right (Item 5) [Figure 16].
- To make a right turn while going in reverse move the Drive / Steering Control Joystick backward and to the left (Item 6) [Figure 16].

STOPPING THE MACHINE

Using The Drive / Steering Control To Stop The Machine

⚠ WARNING

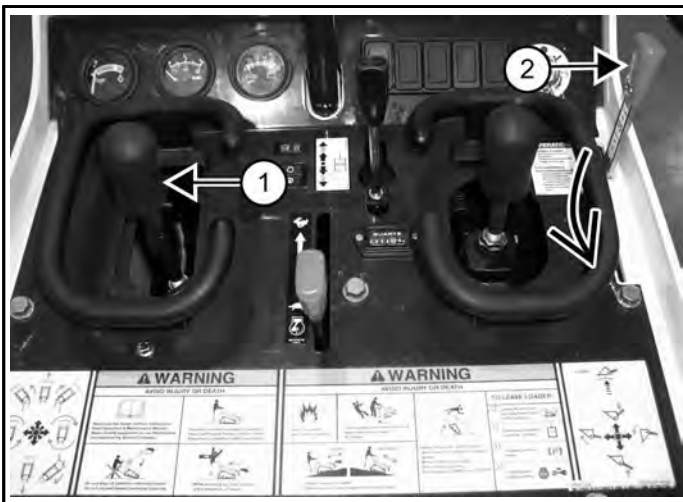
GENERAL HAZARD

Failure to follow instructions can cause serious injury or death. Before you leave the operator's position at the rear of the loader:

- Lower lift arms and put attachment flat on ground.
- Disengage auxiliary hydraulic system.
- Engage parking brake.
- Stop engine. Remove key (if equipped).

W-2416

Figure 17



p124070c

- Move the Drive / Steering Control Joystick (Item 1) [Figure 17] to the neutral position.

Engage the parking brake (Item 2) [Figure 17] before leaving the operator's position.

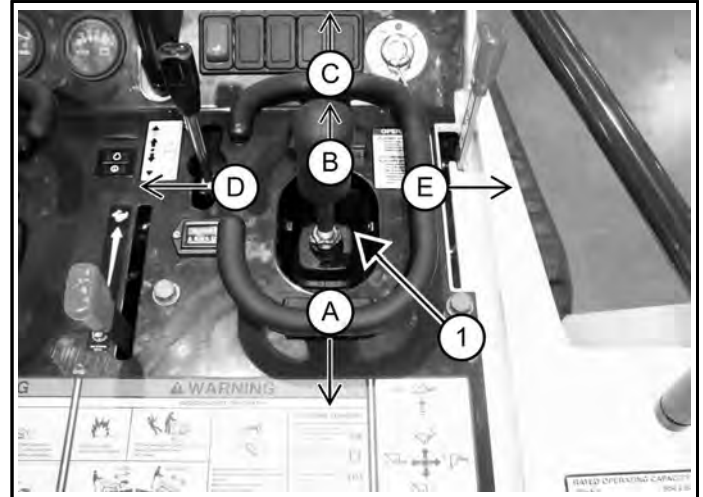
The hydrostatic drive system will act as a service brake to stop the machine.

HYDRAULIC CONTROLS

Lift / Tilt Joystick Description

The Lift / Tilt Control Joystick (Item 1) [Figure 18] controls the movement of the lift arms and the attachment tilt.

Figure 18



p124069b

Lift Arm Operation

REF.	DESCRIPTION
A	Raise Lift Arms
B	Lower Lift Arms

Lift Arm Float Position

REF.	DESCRIPTION
C	Lift Arms in Float Position [A]

[A] Use the float position of the lift arms to level loose material while driving backward.

Tilt Operation

REF.	DESCRIPTION
D	Tilt Attachment Backward
E	Tilt Attachment Forward

Operating The Lift Arm Float Position

1. Push the lift / tilt joystick (Item 1) [Figure 18] all the way forward.
2. Release the joystick to disengage.

NOTE: Use the float position of the lift arms to level loose material while driving backwards.

Auxiliary Hydraulic Control Variable Flow

Figure 19

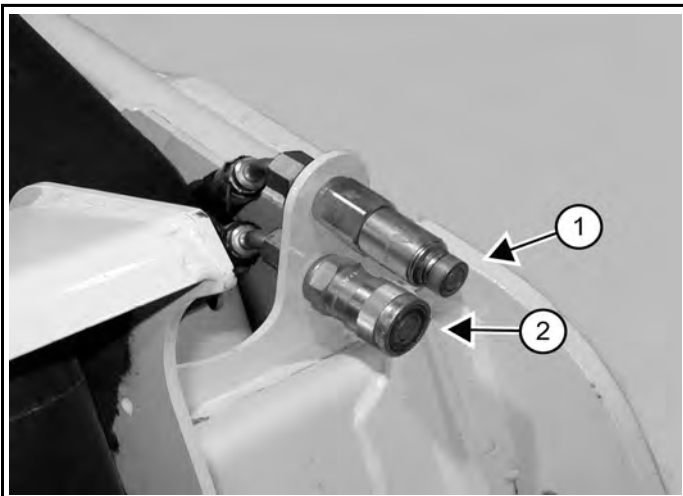


p12406c

- Push the Auxiliary Hydraulic Control Lever (Item 1) [Figure 19] forward for auxiliary hydraulic oil flow to the front male coupler (Item 1) [Figure 20].

Hydraulic oil flow increases to the coupler as the lever is pushed forward.

Figure 20



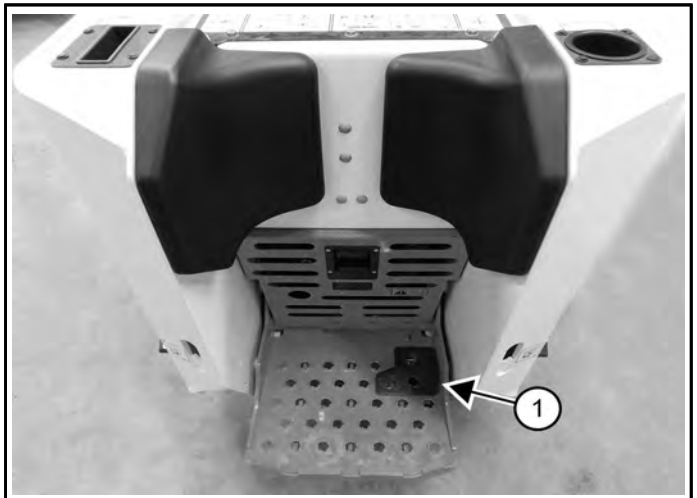
p-81898a

- Pull the Auxiliary Hydraulic Control Lever (Item 1) [Figure 19] backward for auxiliary oil flow to the front female coupler (Item 2) [Figure 20].

Hydraulic oil flow increases to the coupler as the lever is pulled backward.

Auxiliary Hydraulic Control Continuous Flow

Figure 21



c201720b

Figure 22



p12406c

The Auxiliary Hydraulic Lever (Item 1) [Figure 22] must be in neutral and the Continuous Flow Shutoff Pedal (Item 1) [Figure 21] must be released to start the engine.

- While depressing the Continuous Flow Shutoff Pedal (Item 1) [Figure 21], push the Auxiliary Hydraulic Control Lever (Item 1) [Figure 22] all the way forward or all the way backward until it locks (DETENT position) for continuous auxiliary hydraulic oil flow for an attachment such as a tiller or trencher.
- To stop the auxiliary hydraulic oil flow release the Continuous Flow Shutoff Pedal (Item 1) [Figure 21].

Auxiliary Hydraulic Control Lever (Item 1) [Figure 22] will return to NEUTRAL after one to three seconds and the auxiliary hydraulic oil flow will stop.

Standard Auxiliary Quick Couplers

⚠ WARNING

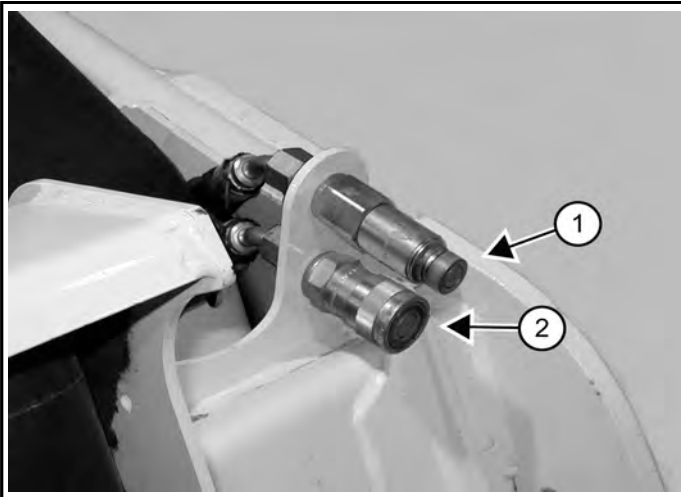
INJECTION HAZARD

Pressurised hydraulic fluid can penetrate skin or eyes, causing serious injury or death. If fluid enters skin or eyes, get immediate medical attention from a doctor familiar with this injury. ◀

W-2145

To Connect:

Figure 23



p-8188a

1. Remove dirt and debris from the surface of both the male and female couplers and from the outside diameter of the male coupler. Visually check the couplers (Item 1) and (Item 2) [Figure 23] for corroding, cracking, damage, or excessive wear. If any of these conditions exist the coupler(s) must be replaced.
2. Install the male couplers into the female couplers. Full connection is made when the ball release sleeve slides forward on the female coupler.

To Disconnect

3. Hold the male coupler and retract the sleeve on the female coupler until the couplers disconnect.

⚠ WARNING

BURN HAZARD

Hydraulic fluid, tubes, fittings and quick couplers can get hot when running machine and attachments. Be careful when connecting and disconnecting quick couplers. ◀

W-2220

Relieve Hydraulic Pressure (Machine And Attachment)

Hydraulic pressure in the auxiliary hydraulic system can make it difficult to engage quick couplers to an attachment.

1. Lower the lift arms fully and put the attachment flat on the ground.
2. Engage the parking brake.
3. Stop the engine.

Figure 24



p124069c

4. Move the Auxiliary Hydraulic Control Lever (Item 1) [Figure 24] forward and backward to release auxiliary hydraulic oil pressure.
5. If attachment is attached:
 - a. Follow the procedure above to release pressure in the machine.
 - b. Connect male coupler from attachment to female coupler of the machine then repeat procedure from above. This will release pressure in the attachment.
 - c. Connect the female coupler from the attachment to the male coupler of the machine. This will release pressure in the attachment.

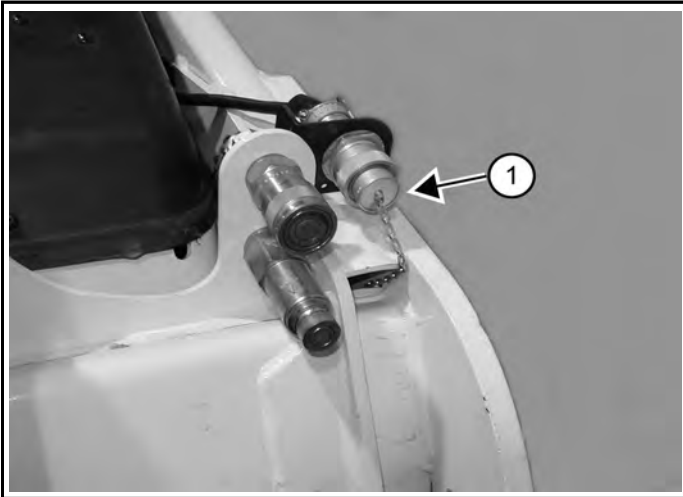
ATTACHMENT CONTROL DEVICE (ACD)

Attachment Control Device (ACD) Description

This machine may be equipped with an optional Attachment Control Device (ACD).

The attachment electrical harness is used to control functions on various attachments that can be used with the machine.

Figure 25



The harness connector (Item 1) [Figure 25] will connect to the electrical harness on various attachments when the attachment is installed on the machine.

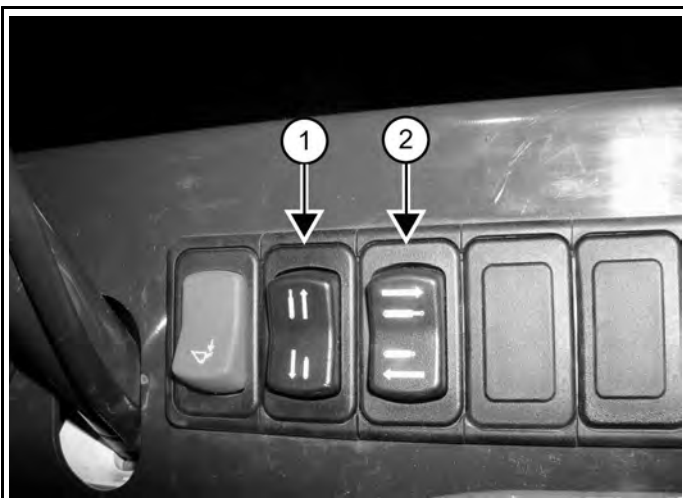
⚠ WARNING

MODIFICATION HAZARD

Modifications or unapproved attachment use can cause serious injury or death. Never modify equipment or use attachments that are not manufactured by Bobcat Company.

W2431

Figure 26



p116998b

The two switches (Item 1) and (Item 2) [Figure 26] are used with the electrical harness to control the movement of different functions on the various attachments.

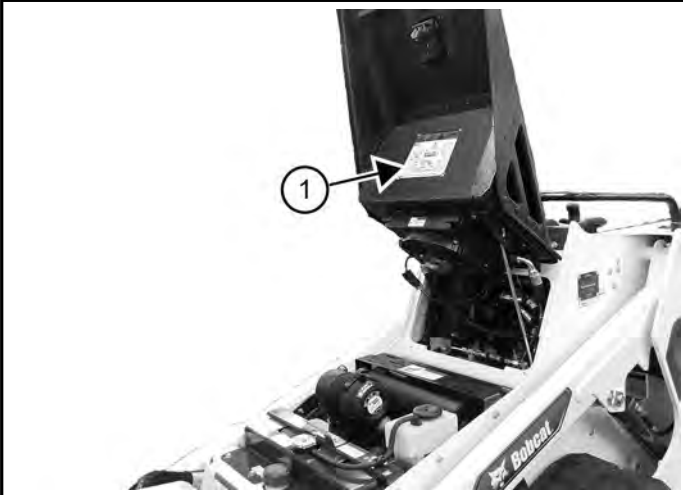
See the appropriate attachment Operation & Maintenance Manual for control details.

DAILY INSPECTION

Daily Inspection And Maintenance

Maintenance work must be done at regular intervals. Failure to do so will result in excessive wear and early failures. The Service Schedule is a guide for correct maintenance of the machine. The decal (Item 1) [Figure 27] is located on the underside of the hood.

Figure 27



- Clean Operator Platform
- Clean Engine Compartment, Oil Cooler, and Radiator
- Check Engine Oil Level
- Hydraulic Fluid Level
- Engine Air Filter, Check Air System for Damage or Leaks
- Engine Coolant Level, Check System for Damage or Leaks
- Fuel Filter, Drain Water From Separator
- Grease Pivot Pins on the Lift Arms, Cylinders, and Bob-Tach or Common Industry Interface
- Grease the Bob-Tach Locking Wedges or Common Industry Interface Locking Pins
- Lift Arm Support, Replace if Damaged or Missing
- Check Tracks for Wear or Damage
- Track Tension
- Check Function of Neutral Start Interlocks and Lift / Tilt Lockouts
- Check Function of the Continuous Flow Shutoff System
- Check Function of Parking Brake

- Safety Signs (Decals) Replace as Necessary
- Loose or Broken Parts, Repair or Replace as Necessary

⚠ WARNING

INSUFFICIENT INSTRUCTIONS HAZARD
Untrained operators or failure to follow instructions can cause serious injury or death. Operators must have adequate training and instruction before operating. ◀

NOTE: Fluids such as engine oil, hydraulic fluid, coolant, etc. must be disposed of in an environmentally safe manner. Some regulations require that certain spills and leaks on the ground must be cleaned in a specific manner. See local, state and federal regulations for correct disposal.

⚠ IMPORTANT

MACHINE DAMAGE HAZARD
Improper pressure washing may lead to damage of the decal.

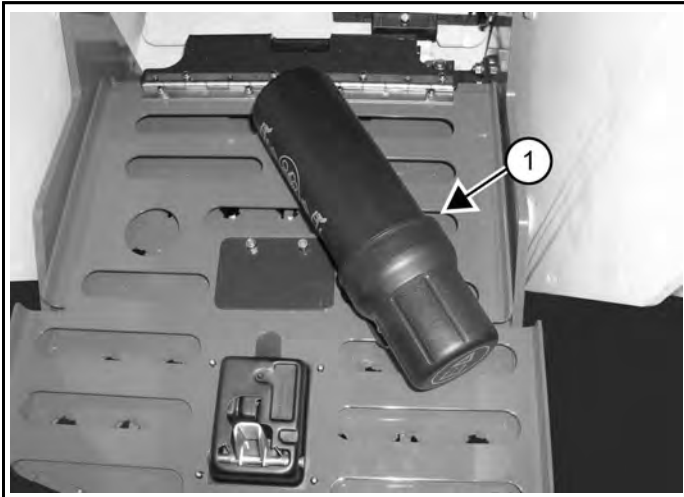
- Direct the stream at a 90 degree angle and at least 300 mm (12 in) from the decal.
- Wash from the centre of the decal toward the edges. ◀

PRE-STARTING PROCEDURE

Pre-Starting Procedure

The engine will not start unless the Drive / Steering Control Joystick and the Auxiliary Hydraulic Control are in neutral. The Continuous Flow Shutoff Pedal must not be depressed when starting the engine.

Figure 28



p116996a

1. Read and understand the Operation & Maintenance Manual stored inside the manual container on the rear door (Item 1) [Figure 28] before operating the machine.

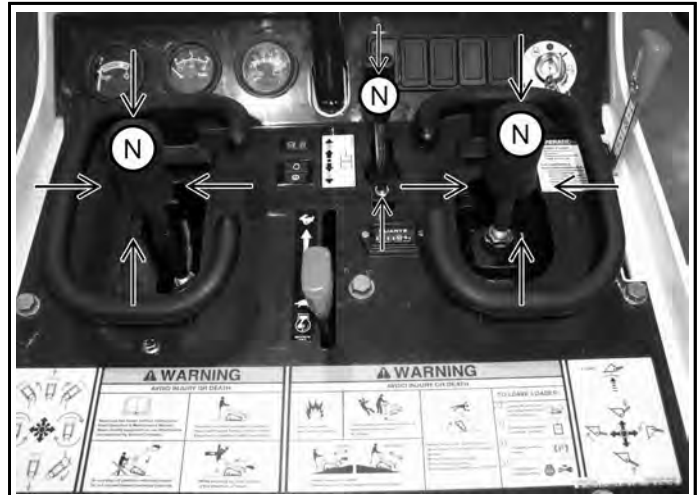
⚠ WARNING

INSUFFICIENT INSTRUCTIONS HAZARD
Untrained operators or failure to follow instructions can cause serious injury or death.

- Read and understand the Operation & Maintenance Manual and decals on machine.
- Follow warnings and instructions in the manuals when making repairs, adjustments, or servicing.
- Check for correct function after adjustments, repairs, or service. ◀

W-2408

Figure 29



p124070d

2. Put all controls in neutral position [Figure 29].

Figure 30



p124074a

3. Verify the parking brake (Item 1) [Figure 30] is engaged.

⚠ WARNING

GENERAL HAZARD
Failure to follow instructions can cause serious injury or death.

When operating the machine:

- Operate only from the operator position at the rear of the loader.
- Always keep your hands on the controls.
- Stay away from the tracks. ◀

W-2407

⚠ WARNING**UNINTENDED MOVEMENT HAZARD**

Attachment movement can cause serious injury or death.

- Movement of the attachment will occur if the lift control is NOT in neutral when the engine is started.
- Always check that all levers are in neutral before starting the engine. ◀

W-2482

STARTING THE ENGINE**Starting Engine With Key Switch**

1. Perform the Pre-Starting Procedure.
(See Pre-Starting Procedure on Page 36)

Figure 31

p124074b

2. Set the engine speed control (Item 1) [Figure 31] to the lowest speed position.

⚠ WARNING**EXPLOSION HAZARD**

Failure to follow instructions can cause serious injury, death or severe engine damage.
DO NOT use ether or starting fluid with glow plug or air intake heater systems. ◀

W-2071

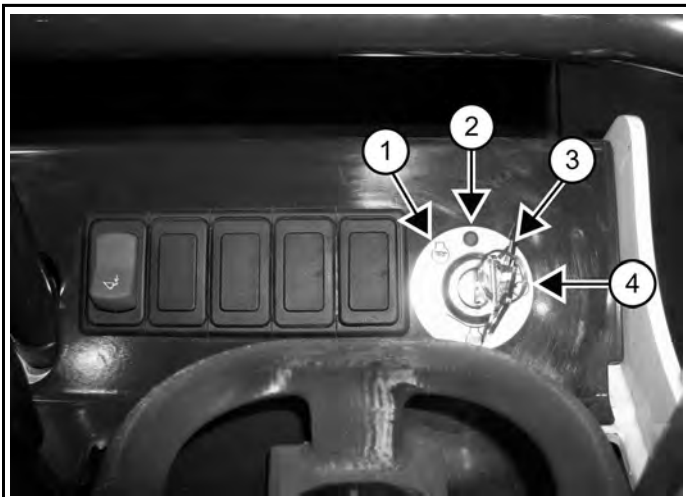
⚠ WARNING**FIRE AND EXPLOSION HAZARDS**

Engines can have hot parts and hot exhaust gas that can cause serious injury or death.

- Keep flammable material away.
- **DO NOT** use machines in an atmosphere containing explosive dust or gases. ◀

W-2051

Figure 32



3. Turn the key to the PREHEAT position (if required) (Item 1) [Figure 32].
- (See Cold Temperature Starting on Page 38)
4. Turn the key to START (Item 4) [Figure 32]. Release the key when the engine starts.
- The key will return to the ON (Item 3) [Figure 32] position.
5. Stop the engine if any warning lights stay on after the engine is running.
- Check for the cause of the warning before starting the engine again.
6. Turn the key OFF (Item 2) [Figure 32] to stop the engine.

⚠ IMPORTANT

MACHINE DAMAGE HAZARD

Damage to the starter motor can occur with prolonged use.

- Do not engage the starter for longer than 15 seconds at a time.
- Allow the starter motor to cool for 1 minute before using again. ◀

I-2034

⚠ WARNING

INHALATION HAZARD

Exhaust fumes contain odorless, invisible gases that can kill without warning.

Fresh air must be added to avoid concentration of exhaust fumes when an engine is running in an enclosed area. If the engine is stationary, vent the exhaust outside. ◀

W-2050

Cold Temperature Starting

⚠ WARNING

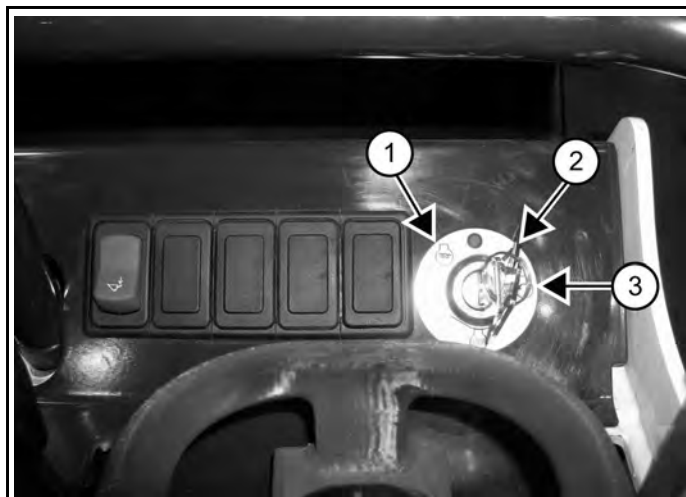
EXPLOSION HAZARD

Failure to follow instructions can cause serious injury, death or severe engine damage.

DO NOT use ether or starting fluid with glow plug or air intake heater systems. ◀

W-2071

Figure 33



p116991b

- If the temperature is below freezing, perform the following to make starting the engine easier:
 - Replace the engine oil with the correct type and viscosity for the anticipated starting temperature. (See Engine Lubrication System on Page 70)
 - Make sure the battery is fully charged.
 - Turn the key to PREHEAT position (Item 1) [Figure 33]. Preheat for 15 seconds maximum.
 - Turn the key to START (Item 3) [Figure 33]. Release the key when the engine starts.
- It will return to ON (Item 2) [Figure 33] position.
- Stop the engine if the warning lights stay on after the engine is running.
 - Check for the cause of the warning before starting the engine again.

Warming The Hydraulic / Hydrostatic System

Let the engine run at moderate speed to warm the engine and hydraulic fluid before operating the machine.

⚠ IMPORTANT**MACHINE DAMAGE HAZARD**

Failure to follow directions can result in machine damage.

Starting the engine when the temperature of the hydraulic fluid is less than -29°C (-20°F) will result in significant damage to the hydraulic system and components.

Park the machine in a heated location or provide some means of warming the hydraulic fluid prior to starting the engine if the ambient temperature at startup is expected to be -29°C (-20°F) or below.

I-2403

STOPPING THE ENGINE AND LEAVING THE MACHINE**Stopping The Engine And Leaving The Machine Procedure**

1. Stop the machine on level ground.

Figure 34

C201718

2. Lower the lift arms fully and put the attachment flat on the ground [Figure 34].
3. Disengage the auxiliary hydraulics.
4. Move the engine speed control fully down to decrease the engine speed.
5. Engage the parking brake.
6. Turn the key OFF (Item 2) [Figure 32].
7. Remove the key to prevent operation of machine by unauthorised personnel.
8. Step off the operator platform.

⚠ WARNING**GENERAL HAZARD**

Failure to follow instructions can cause serious injury or death.

Before you leave the operator's position at the rear of the loader:

- Lower lift arms and put attachment flat on ground.
- Disengage auxiliary hydraulic system.
- Engage parking brake.
- Stop engine. Remove key (if equipped).

W-2416

ATTACHMENTS

Rated Operating Capacity Description

⚠ WARNING

INSTABILITY HAZARD

Excessive load can cause loss of control or tipping leading to serious injury or death. DO NOT exceed ROC.

The ROC for this machine is shown on a decal in the operator cab.
(See Safety And Training Resources on Page 12) The buckets and attachments are approved for ROC and for secure fastening to the Bob-Tach system.

NOTE: The ROC of a machine can be different depending on which undercarriage is equipped with the machine.

The ROC for a machine is determined by using a specification bucket and material of normal density, such as dirt or dry gravel. Using a different bucket changes the machine's ROC.
(See Calculating The Rated Operating Capacity For Buckets on Page 41) Options such as larger buckets, counterweights, or rear stabilisers also impact the machine's ROC. If extremely dense material is loaded, the volume must be reduced to prevent overloading.

The weights for attachments can be found in documentation, including serial number plates, name plates, in the attachment Operation & Maintenance Manual, or by contacting your Bobcat dealer.

Choosing The Correct Attachment

⚠ WARNING

MODIFICATION HAZARD

Unapproved attachments can cause serious injury or death. Buckets and attachments for safe loads of specified densities are approved for each model. Never use attachments or buckets that are not approved by Bobcat Company.

NOTE: Warranty void if non-approved attachments are used on Bobcat machine.

The dealer can identify, for each model machine, the attachments and buckets approved by Bobcat Company. The buckets and attachments are approved for ROC and for secure fastening to the machine.

The ROC for this machine is shown on a decal on the machine. (See Specifications on Page 92)

The ROC is determined by using a standard dirt bucket and material of normal density, such as dirt or dry gravel. If longer buckets are used, the load centre moves forward and reduces the ROC. If very dense material is loaded, the volume must be reduced to prevent overloading.

Exceeding the ROC can cause the following problems:

- Difficult steering.
- Faster track wear.
- Loss of stability.
- Reduced machine life.

Use the correct size bucket for the type and density of material being handled. For safe handling of materials and to avoid machine damage, the attachment (or bucket) should handle a full load without going over the ROC for the machine. Partial loads make steering more difficult.

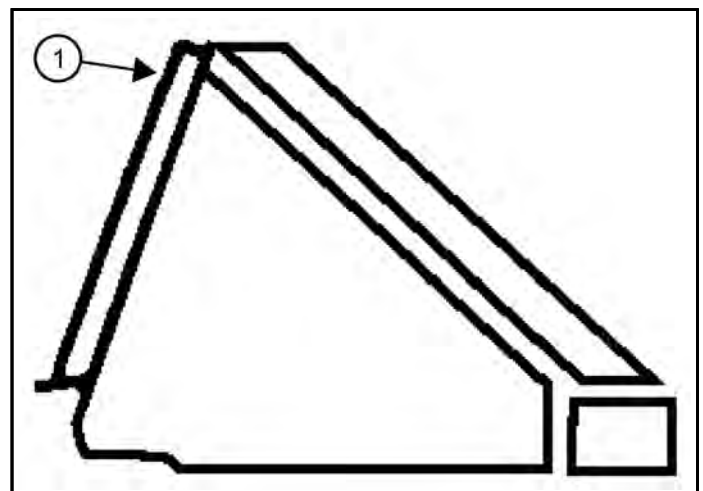
Calculating The Rated Operating Capacity For Buckets

The ROC for a machine is determined by using a specification bucket and material of normal density, such as dirt or dry gravel. Using a different bucket changes the machine's ROC. Options such as larger buckets, counterweights, or rear stabilisers also impact the machine's ROC. If extremely dense material is loaded, the volume must be reduced to prevent overloading. Use the following process to estimate the ROC for other approved buckets. This process does not take variable bucket lengths and centers of gravity into account.

1. Find the ROC for the machine.
(See Safety And Training Resources on Page 12)
2. Add the weight of the specification bucket to the ROC.

Machine ROC (A)
Specifications Bucket Weight (B)
New Bucket (C)
 $A + B = D$
 $D - C =$ Estimated Adjusted ROC with new bucket

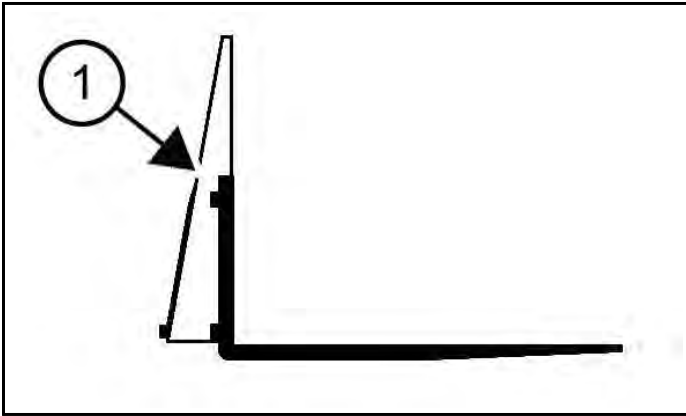
Figure 37



3. Subtract the weight of the new bucket to be used. Many buckets have a plate or stamped information located on the bucket (Item 1) [Figure 37].

Pallet Fork

Figure 38



b-17255a

If a pallet fork attachment is used, the load centre moves forward and reduces the load capacity.

The maximum load to be carried when using a pallet fork is shown on a decal located on the pallet fork frame (Item 1) [Figure 38].

⚠ WARNING

INSTABILITY HAZARD
Excessive load can cause loss of control or tipping leading to serious injury or death.
DO NOT exceed ROC.

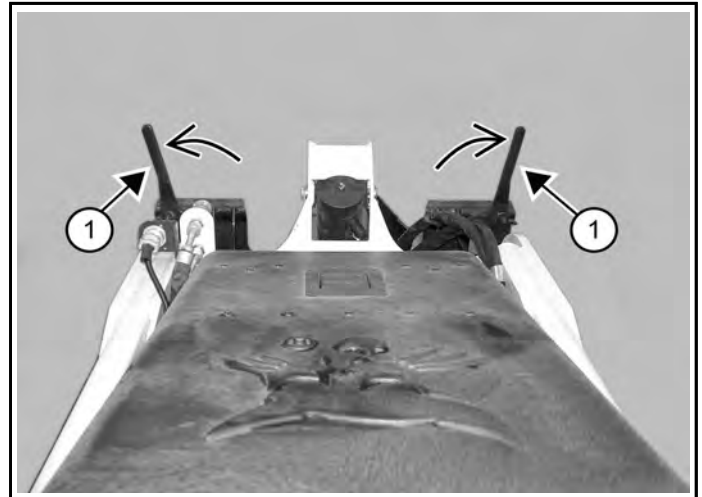
W2053

See your Bobcat Dealer for more information about pallet fork inspection, maintenance and replacement. See your Bobcat Dealer for ROC when using pallet fork and for other available attachments.

Installing The Attachment (Bob-Tach System)

The Bob-Tach attachment mounting system is used for fast changing of buckets and other attachments. Installation and removal of a bucket is shown. See the appropriate attachment Operation & Maintenance Manual to install other attachments.

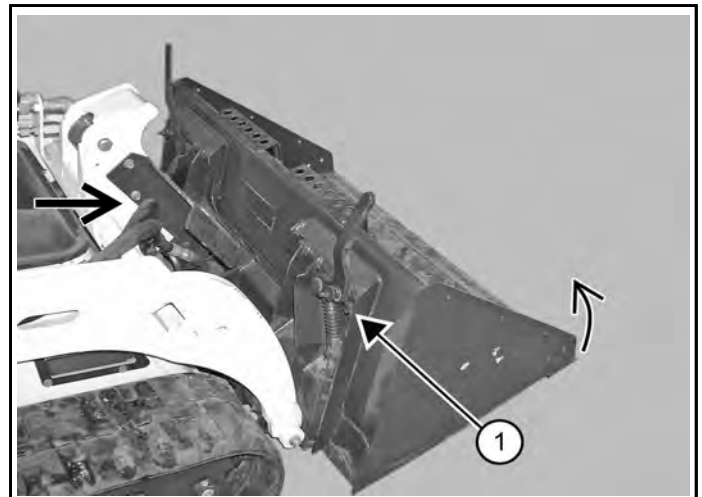
Figure 39



p-61862a

1. Pull the Bob-Tach levers (Item 1) [Figure 39] all the way up.
2. Perform the Pre-Starting Procedure. (See Pre-Starting Procedure on Page 36)
3. Start the engine.
4. Release the parking brake.
5. Lower the lift arms and tilt the Bob-Tach attachment mounting system forward.

Figure 40

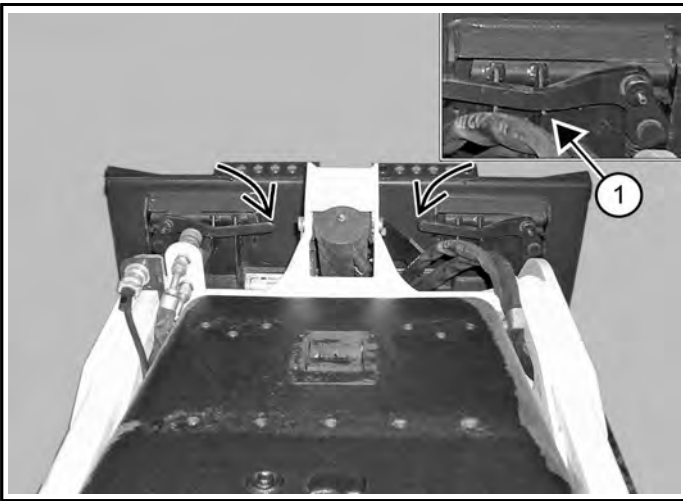


p-61861a

6. Drive forward until the top of the Bob-Tach attachment mounting system is completely under the top flanges of the bucket (Item 1) [Figure 40] (or other attachment). Be sure the Bob-Tach levers do not hit the bucket.
7. Tilt the Bob-Tach attachment mounting system backward until the cutting edge of the bucket (or other attachment) is slightly off the ground [Figure 40].

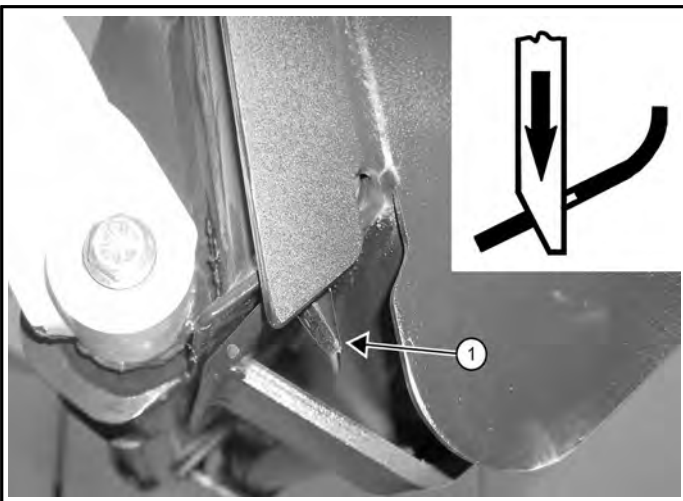
8. Stop the engine.
9. Engage the parking brake.

Figure 41



10. Push the Bob-Tach levers down until they are fully engaged in the locked position (Item 1) [Figure 41] (wedges fully extended).

Figure 42



11. Ensure the wedges (Item 1) [Figure 42] must extend through the holes in the mounting frame of the bucket (or attachment), securely fastening the bucket to the Bob-Tach attachment mounting system.

⚠ WARNING

CRUSHING HAZARD
 Failure to secure Bob-Tach wedges can allow attachment to come off and cause serious injury or death.
 Both wedges must extend through the holes in the attachment mounting frame. Lever(s) must be fully down and locked. ◀

Removing The Attachment (Bob-Tach System)

1. Lower the lift arms, put the attachment flat on the ground and lower or close the hydraulic equipment.
2. Stop the engine.
3. Engage the parking brake.
4. If the attachment is hydraulically controlled, stop the engine and relieve hydraulic pressure at the quick couplers. (See Relieve Hydraulic Pressure (Machine And Attachment) on Page 33)

⚠ WARNING

GENERAL HAZARD

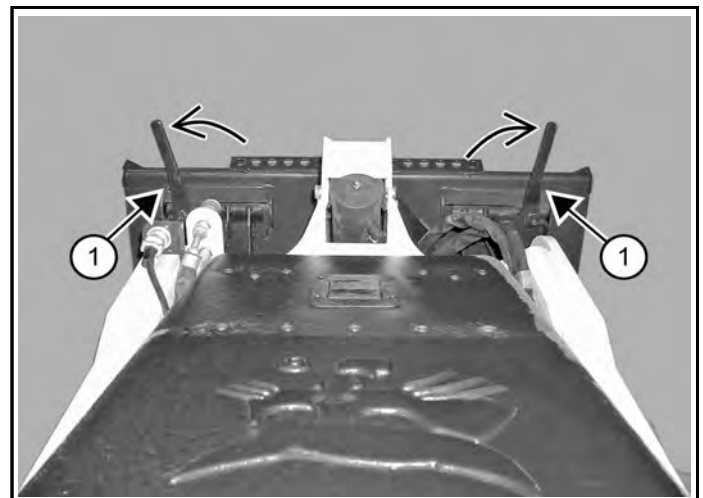
Failure to follow instructions can cause serious injury or death.

Before you leave the operator's position at the rear of the loader:

- Lower lift arms and put attachment flat on ground.
- Disengage auxiliary hydraulic system.
- Engage parking brake.
- Stop engine. Remove key (if equipped). ◀

5. Disconnect auxiliary hydraulic hoses.

Figure 43



6. Pull the Bob-Tach levers (Item 1) [Figure 43] all the way up.
7. Perform the Pre-Starting Procedure. (See Pre-Starting Procedure on Page 36)
8. Start the engine.
9. Release the parking brake.
10. Ensure the lift arms are all the way down. Tilt the Bob-Tach attachment mounting system forward. Move backward, away from the bucket or attachment.

Installing The Attachment (Common Industry Interface)

The Common Industry Interface (CII) is used for fast changing of buckets and other attachments. See the appropriate attachment Operation & Maintenance Manual for further instructions.

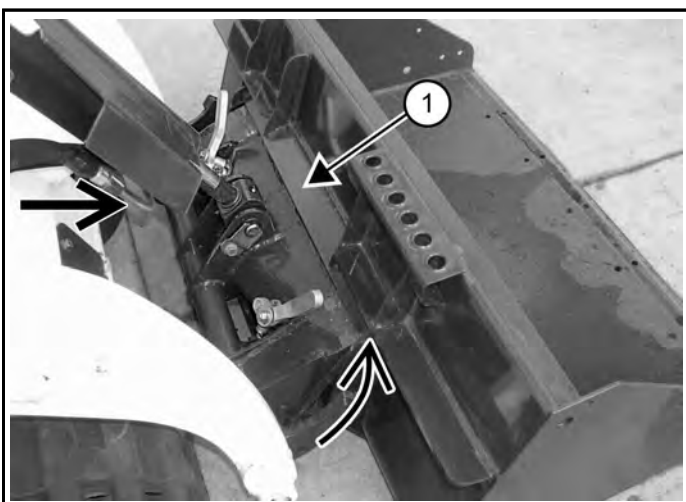
Figure 44



p124033a

1. Pull the CII locking pins all the way up [Figure 44].
2. Perform the Pre-Starting Procedure. (See Pre-Starting Procedure on Page 36)
3. Start the engine.
4. Release the parking brake.
5. Lower the lift arms and tilt the CII forward.

Figure 45



p124034a

6. Drive forward until the top of the CII is completely under the top flange of the bucket (Item 1) [Figure 45] (or other attachment).

7. Tilt the CII backward until the front of the bucket (or other attachment) is slightly off the ground.
8. Stop the engine.
9. Engage the parking brake.

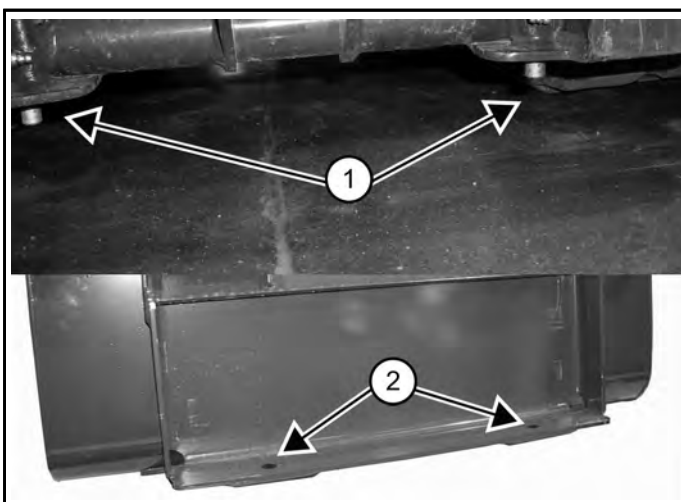
Figure 46



p124035

10. Push the CII locking pin levers down until they are fully engaged in the locked position [Figure 46] (pins fully extended).

Figure 47



c205327a

11. The pins (Item 1) must extend through the holes in the mounting frame of the bucket (or other attachment) (Item 2) [Figure 47], securely fastening the attachment to the interface.

⚠ WARNING

CRUSHING HAZARD

Failure to secure the locking pins can allow attachment to come off and cause serious injury or death.

- Both Common Industry Interface locking pins must extend through the holes in attachment frame.
- Lever must be fully down and locked. ◀

W-2996

Removing The Attachment (Common Industry Interface)

1. Lower the lift arms, put the attachment flat on the ground and lower or close the hydraulic equipment.
2. Stop the engine.
3. Engage the parking brake.
4. If the attachment is hydraulically controlled (combination bucket, tiller, etc.) stop the engine and relieve hydraulic pressure at the quick couplers. (See Relieve Hydraulic Pressure (Machine And Attachment) on Page 33) Disconnect auxiliary hydraulic hoses.

⚠ WARNING

GENERAL HAZARD

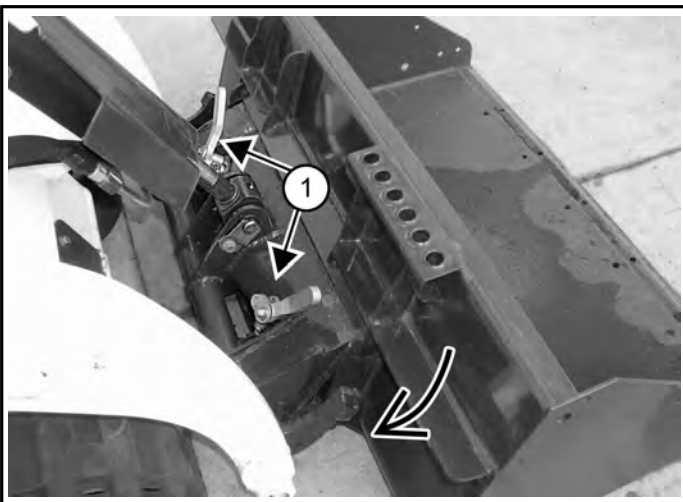
Failure to follow instructions can cause serious injury or death.

Before you leave the operator's position at the rear of the loader:

- Lower lift arms and put attachment flat on ground.
- Disengage auxiliary hydraulic system.
- Engage parking brake.
- Stop engine. Remove key (if equipped). ◀

W-2416

Figure 48



p129034b

5. Pull the CII locking pin levers (Item 1) [Figure 48] all the way up.

6. Perform the Pre-Starting Procedure. (See Pre-Starting Procedure on Page 36)
7. Start the engine.
8. Release the parking brake.
9. Ensure the lift arms are all the way down. Tilt the Common Industry Interface forward.
10. Move backward, away from the bucket or attachment.

OPERATING PROCEDURE

Inspect The Work Area

Before beginning operation, inspect the work area and check ground conditions for unsafe conditions:

- Look for sharp drop-offs or rough terrain.
- Have underground utility lines (gas, electrical, water, sewer, irrigation, etc.) located and marked.
- Work slowly in areas of underground utilities.
- Remove objects or other construction material that could damage the machine or cause personal injury.
- Inspect for signs of instability such as cracks or settlement.
- Be aware of weather conditions that can affect ground stability.
- Check for adequate traction if working on a slope.

Basic Operating Instructions

Always warm the engine and hydrostatic system before operating the machine.

Operate the machine with engine at full speed for maximum horsepower. Move the Drive / Steering Control Joystick only a small amount to operate the machine slowly.

New operators must operate the machine in an open area without bystanders. Operate the controls until the machine can be handled at an efficient and safe rate for all conditions of the work area.

Operating Near An Edge Or Water

Keep the machine as far back from the edge as possible and the machine base perpendicular to the edge so that if part of the edge collapses, the machine can be moved back.

Always move the machine back at any indication the edge may be unstable.

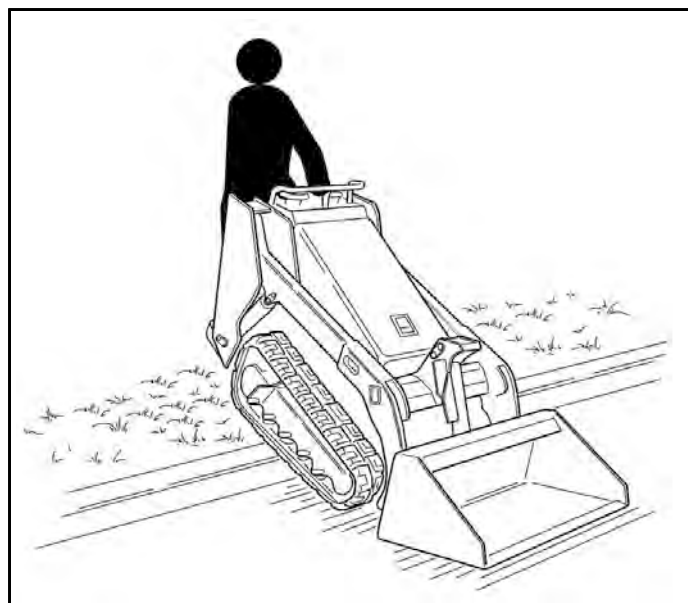
Driving On Rough Terrain And Over Kerbs

Figure 49



NA20027

Figure 50



NA18991

Drive slowly when operating on rough terrain. Always carry the bucket or attachment as low as possible.

When the machine climbs over a kerb and the centre of gravity goes past the kerb, it will tip forward (or backward) quickly [Figure 49] and [Figure 50]. Be careful to keep your feet and body inside the operator position and away from the tracks at all times.

⚠ WARNING

GENERAL HAZARD

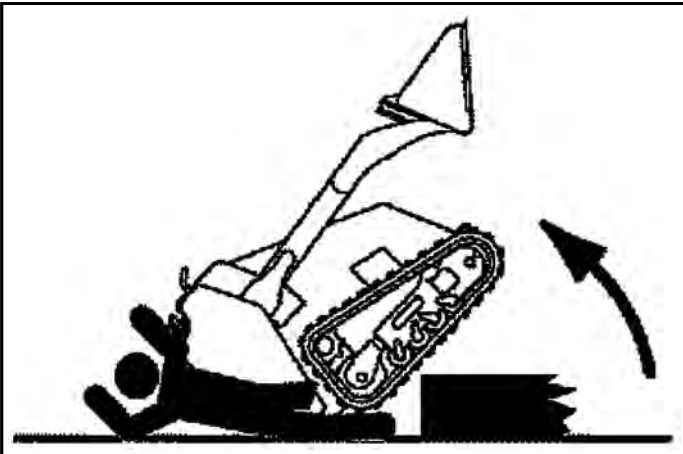
Failure to follow instructions can cause serious injury or death.

When operating the machine:

- Operate only from the operator position at the rear of the loader.
- Always keep your hands on the controls.
- Stay away from the tracks. ◀

W-2407

Figure 51



8737041A

Never back off a kerb or step with no load or with lift arms raised [Figure 51].

If you will be repeatedly driving over a kerb or slope, build a ramp with dirt to make the ascent more gradual.

NOTE: Always keep the heavy end uphill.

Always warm the engine and hydraulic system before operating the machine.

For maximum performance, run the engine at full speed while working.

Move the Drive / Steering Control Joystick only a small amount to operate the machine slowly.

New operators must operate the machine in an open area without bystanders. Operate the controls until the machine can be handled at an efficient and safe rate for all conditions of the work area.

Driving With An Auger Attachment Installed

Only light duty auger bits are approved by Bobcat Company for use on the machine. (Light duty auger bits are factory painted white.)

⚠ WARNING

MODIFICATION HAZARD

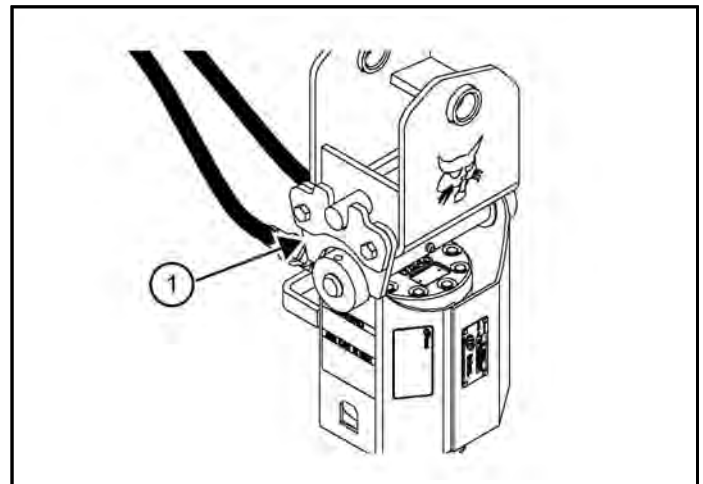
Unapproved attachments can cause serious injury or death.

Buckets and attachments for safe loads of specified densities are approved for each model. Never use attachments or buckets that are not approved by Bobcat Company. ◀

W-2052

- The swing stop kit must be installed on the auger before installing on the machine. Drive slowly with the auger installed. Always carry the auger as low as possible.

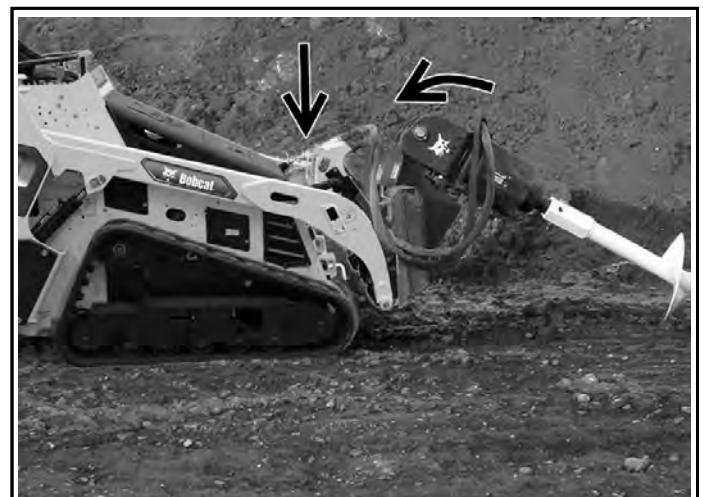
Figure 52



pe-1510c

- The auger swing stop kit (Item 1) [Figure 52] must be installed on the auger before using this attachment on the machine.

Figure 53



p-60970d

- When driving the machine with the auger installed, always have the attachment interface rolled back fully [Figure 53].

- Lower the machine arms [Figure 53] so that the auger bit is just off the ground. Slow down when travelling.
- See the Direct Drive Auger Operation & Maintenance Manual for additional information.

Operating With A Full Bucket

Figure 54



NA20011

Figure 55



NA18992

Keep the heavy end uphill. With a full bucket, the front of the machine is the heavy end [Figure 54] and [Figure 55].

Operating With An Empty Bucket

Figure 56



NA2013

Figure 57



NA20012

Keep the heavy end uphill. With empty bucket, the rear of the machine is the heavy end [Figure 56] and [Figure 57].

Go directly up or down a slope; never across a slope or kerb.

⚠ WARNING

INSTABILITY HAZARD

Machine tipping or rollover can cause serious injury or death.

- Do not overload the machine.
- Keep the lift arms as low as possible.
- Do not travel or turn with the lift arms up.
- Turn on level ground. Slow down when turning.
- Go up and down slopes, not across them.
- Keep the heavy end of the machine uphill.
- Check for adequate traction. ◀

W-2018

TRANSPORTING THE MACHINE

Loading And Unloading The Machine On A Trailer

⚠ WARNING

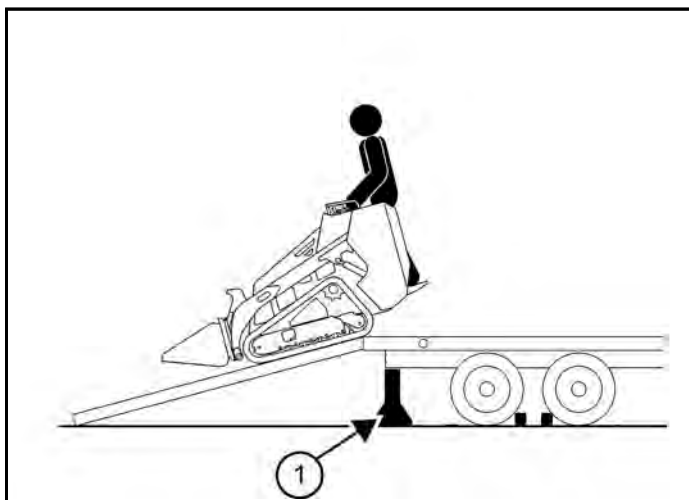
INSTABILITY HAZARD

Wood ramps can break and cause personal injury. Use adequately designed ramps of sufficient strength to support the weight of the machine loading onto a transport vehicle. †

W-2058

Be sure the trailer or vehicle and ramps are of adequate size and capacity. (See Performance on Page 96)

Figure 59



NA18994a

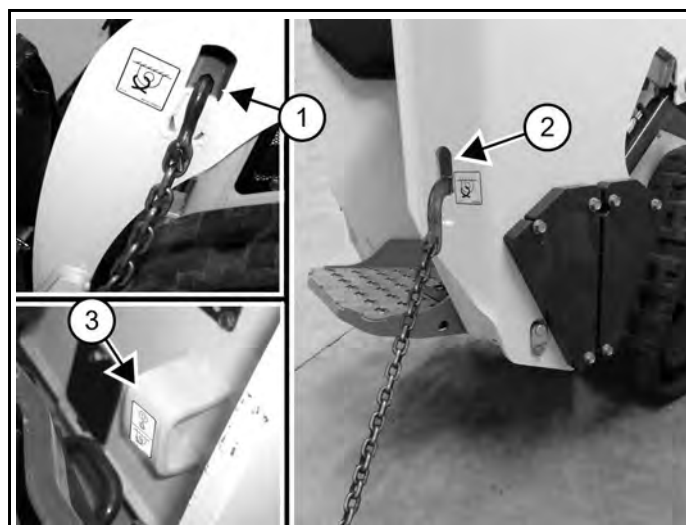
A machine with an empty bucket or no attachment must be loaded backward onto the transport vehicle [Figure 59].

When using adjustable ramps, be sure the ramp width and spacing adequately covers the tread width. Do not attempt to use ramps that are improperly sized.

The rear of the trailer must be blocked or supported (Item 1) [Figure 59] when loading or unloading the machine to prevent the front end of the trailer from raising up.

Fastening The Machine

Figure 60



C201759A

1. Fasten the machine to the transport vehicle to prevent it from moving during sudden stops or when going up or down slopes [Figure 60].
2. Lower the bucket or attachment fully.
3. Stop the engine.
4. Install chains at the front (Item 1) and rear tie-down (Item 2) positions (both sides). The alternate front tie-down (Item 3) [Figure 60] can also be used.
5. Fasten each end of the chain to the transport vehicle.
6. Use load binders to tighten the chains.

MAINTENANCE SAFETY WARNINGS



- Never service the Bobcat machine without instructions. Read and understand the Operation & Maintenance Manual, and signs (decals) on machine.
- Follow warnings and instructions in manuals when making repairs, adjustments or servicing. Check for correct function after adjustments, repairs or service. Untrained operators and failure to follow instructions can cause injury or death.

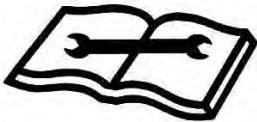
Maintenance procedures which are given in the Operation & Maintenance Manual can be performed by the owner/operator without any specific technical training. Maintenance procedures which are not in the Operation & Maintenance Manual must be performed **ONLY BY QUALIFIED BOBCAT SERVICE PERSONNEL**. Always use genuine Bobcat replacement parts.



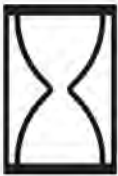
This check mark means: "Follow instructions for proper operations." Carefully read the message that follows.



- Never go under lift arm when raised unless lift arm is held by an approved lift arm support. Replace if damaged.
- Disconnecting or loosening any hydraulic tubeline, hose, fitting, component, or a part failure can cause lift arm to drop.



- Keep body, jewelry, and clothing away from moving parts, electrical contact, hot parts, and exhaust.
- Wear eye protection to guard from battery acid, compressed springs, fluids under pressure, and flying debris when engines are running or tools are used. Use eye protection approved for type of welding.
- Keep engine cover and panels installed except for service. Fasten panels and latch engine cover before operating.



- Cleaning and maintenance are required daily.
- Never modify equipment or add attachments not approved by Bobcat.

2. Stand on the operator platform and engage the parking brake [Figure 61].
3. Start the engine.
4. Raise the lift arms 914 mm (3 ft) off the ground.
5. Stop the engine.
6. Press and hold the switch for the lift arm bypass (Item 1) [Figure 61].
7. Move the Lift Arm / Tilt Control Joystick forward slightly (Item 2) [Figure 61].

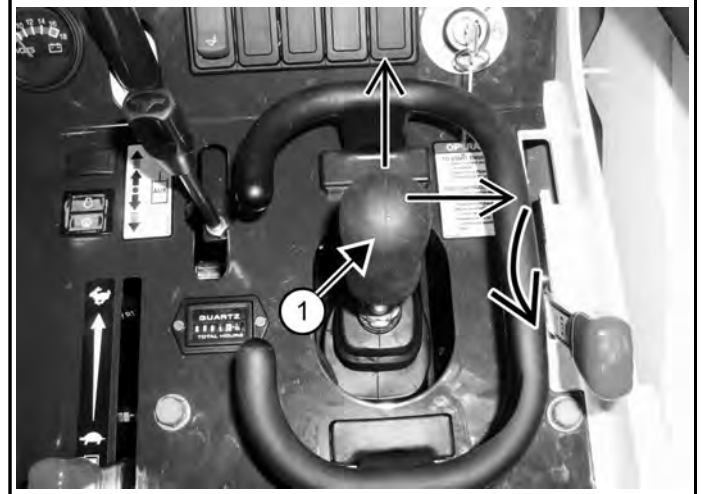
The lift arms should slowly lower. See your Bobcat dealer for repair if bypass does not function correctly.

LIFT AND TILT FUNCTION LOCKOUTS

Inspecting Lift And Tilt Function Lockouts

1. Make sure the area around the machine is clear of bystanders.

Figure 62



2. Stand on operator platform and engage the parking brake [Figure 62].
3. Start the engine.
4. Raise the lift arms about 914 mm (3 ft) off the ground.
5. Stop the engine.
6. Move the Lift Arm / Tilt Control Joystick forward to lower the lift arms (Item 1) [Figure 62].

The joystick must not move and the lift arms must not lower.

7. Move the Lift Arm / Tilt Control Joystick right to tilt the bucket (or attachment) forward (Item 1) [Figure 62].

NOTE: See your Bobcat dealer for repair if the lift / tilt lockout does not function properly.

The joystick must not move and the bucket must not tilt forward.

⚠ WARNING

GENERAL HAZARD

Failure to follow instructions can cause serious injury or death.

The Neutral Start Interlock, Auxiliary Hydraulic Interlock, and Lift / Tilt Lockouts must function properly.

- The Neutral Start Interlock must prohibit the engine from cranking when the Drive / Steering Joystick is not in the NEUTRAL position.
- The Auxiliary Hydraulic Interlock must prohibit the engine from cranking when the Auxiliary Hydraulic Control Lever is not in the center position.
- The Lift / Tilt Lockouts must deactivate the lift and tilt functions when engine is off.

If any of these do not function properly, contact your dealer for service. DO NOT modify system. ◀

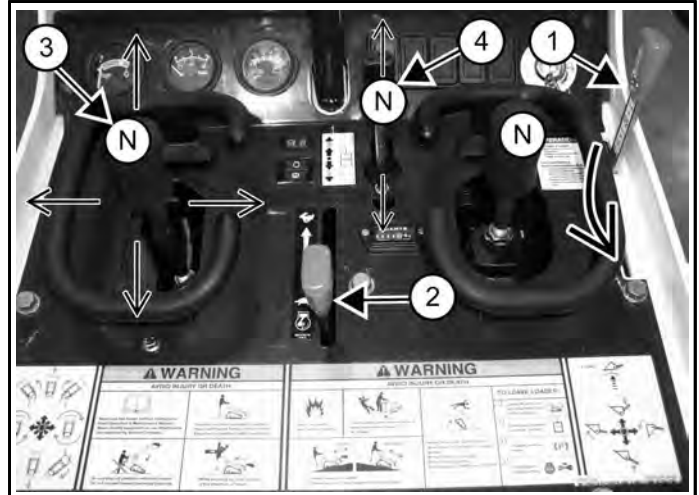
W2998

NEUTRAL START INTERLOCKS

Inspecting Traction Drive Interlock

1. Make sure the area around the machine is clear of bystanders.

Figure 63



p124070e

2. Engage the parking brake (Item 1) [Figure 63].
3. Place all controls in neutral.
4. Stop the engine.
5. Set the engine speed to slow (Item 2) [Figure 63].
6. Partially move the Drive / Steering Control Joystick (Item 3) [Figure 63] in the forward direction and turn the key switch to start position.
The starter must not engage.
7. Repeat procedure with the Drive / Steering Control Joystick being moved in the backward direction.
8. Repeat procedure with the Drive / Steering Control Joystick being moved in the right direction.
9. Repeat procedure with the Drive / Steering Control Joystick being moved in the left direction.

Inspecting Auxiliary Hydraulic Interlock

1. Make sure the area around the machine is clear of bystanders.
2. Engage the parking brake (Item 1) [Figure 63].
3. Place all controls in neutral.
4. Stop the engine.
5. Set the engine speed lever (Item 2) [Figure 63] to slow.

6. Push and hold the Auxiliary Hydraulic Control Lever forward (Item 4) [Figure 63] and turn the key switch to start position.

The starter must not engage.

7. Repeat procedure with the Auxiliary Hydraulic Control Lever pulled backward.

NOTE: If any of the controls in these previous inspection procedures do not function properly, contact your Bobcat dealer for service. Do not modify the system.

⚠ WARNING

GENERAL HAZARD

Failure to follow instructions can cause serious injury or death.

The Neutral Start Interlock, Auxiliary Hydraulic Interlock, and Lift / Tilt Lockouts must function properly.

- The Neutral Start Interlock must prohibit the engine from cranking when the Drive / Steering Joystick is not in the NEUTRAL position.
- The Auxiliary Hydraulic Interlock must prohibit the engine from cranking when the Auxiliary Hydraulic Control Lever is not in the center position.
- The Lift / Tilt Lockouts must deactivate the lift and tilt functions when engine is off.

If any of these do not function properly, contact your dealer for service. DO NOT modify system. ◀

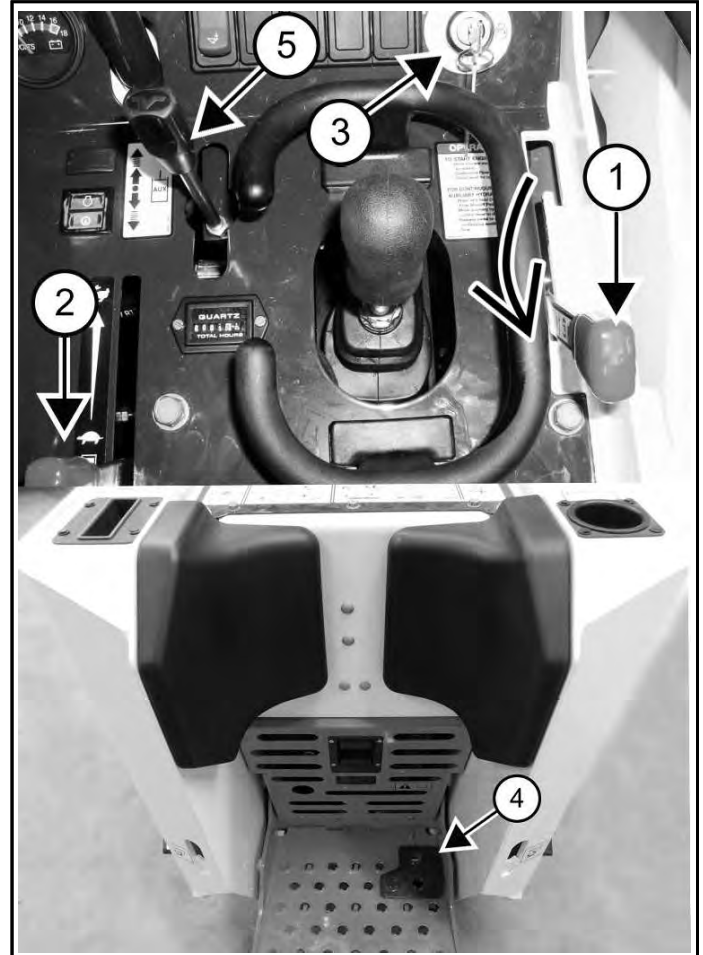
W-2988

AUXILIARY HYDRAULIC CONTROL SYSTEM

Inspecting The Continuous Flow Shutoff Pedal

1. Make sure the area around the machine is clear of bystanders.

Figure 64



2. Engage the parking brake (Item 1) [Figure 64].
3. Stop the engine.
4. Set the engine speed to slow (Item 2) [Figure 64].
5. Turn the key to the ON position (Item 3) [Figure 64] but do not start the engine.
6. Stand on the Operator Platform and depress the Continuous Flow Shutoff Pedal (Item 4) [Figure 64].
7. Move the Auxiliary Hydraulic Control Lever (Item 5) [Figure 64] fully forward into the locked (DETENT) position.
8. Release the Continuous Flow Shutoff Pedal (Item 4) [Figure 64].

The Auxiliary Hydraulic Control Lever (Item 5) [Figure 64] must return to the neutral position in approximately one to three seconds.

9. Repeat the procedure with the Auxiliary Hydraulic Control Lever (Item 5) [Figure 64] fully backward into the locked (DETENT) position.

NOTE: Contact your Bobcat dealer for service if the Continuous Flow Shutoff System does not function properly.

LIFT ARM SUPPORT

Installing Lift Arm Support

⚠ DANGER

CRUSHING HAZARD

Failure to follow instructions will cause serious injury or death.

- Disconnecting hydraulic lines can cause the lift arms or attachment to drop.
- Always use an approved lift arm support when lift arms are in a raised position. ◀

D-1008

⚠ WARNING

CRUSHING HAZARD

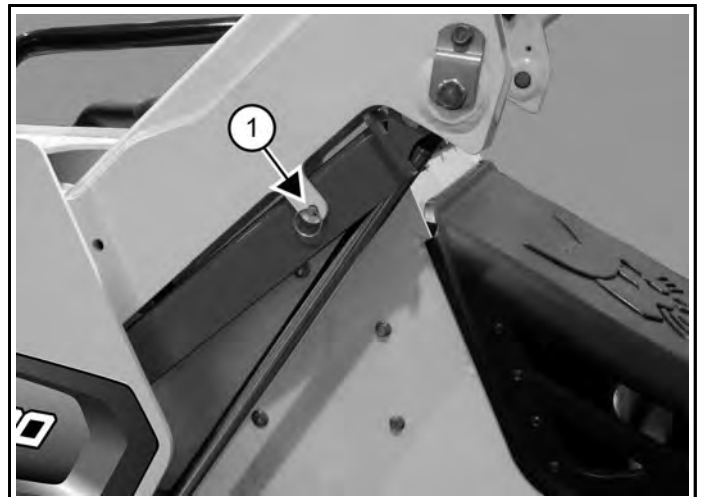
Using a damaged support device or with missing parts can cause lift arms or boom to fall causing serious injury or death.

Service or replace the support device if damaged or if parts are missing. ◀

W-2271

1. Remove any attachment from the machine.
(See Removing The Attachment (Bob-Tach System) on Page 43)
(See Removing The Attachment (Common Industry Interface) on Page 45)
2. Stop the machine on a flat, level surface.
3. Engage the parking brake.
4. Start the engine, and raise the lift arms all the way up.
5. Stop the engine and exit the operator position.

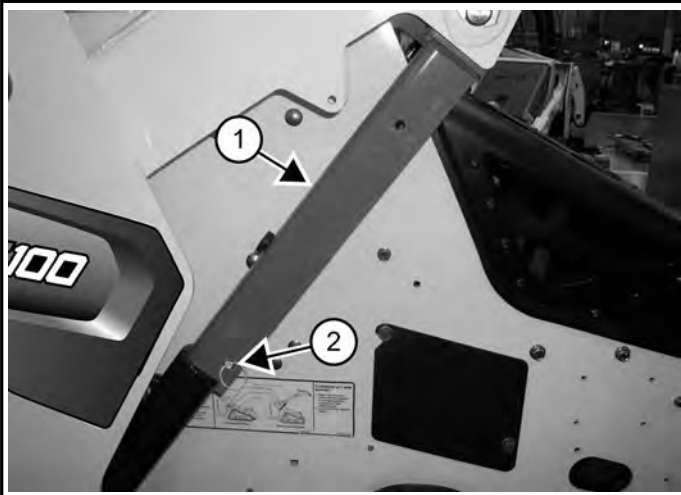
Figure 65



C201760A

6. Remove the retainer pin (Item 1) and lower the lift arm support from the storage position.

Figure 66



C201761A

7. Place the lift arm support (Item 1) over the hydraulic cylinder as shown in [Figure 66].
8. Install the retaining pin (Item 2) [Figure 66] into the rear of the lift arm support below the cylinder rod.
9. Enter the operator position and start the engine.
10. Slowly lower the lift arms until movement stops.
11. Stop the engine.

Removing The Lift Arm Support

1. Remove the retaining pin (Item 2) [Figure 66] from the lift arm support.
2. Start the engine and raise the lift arms off the lift arm support.
3. Stop the engine and exit the operator position.
4. Return the lift arm support to the storage location and secure it with the retaining pin (Item 1) [Figure 65].
5. Enter the operator position and start the engine.
6. Lower the lift arms and stop the engine.

HOOD

Raising And Lowering The Hood

⚠ WARNING

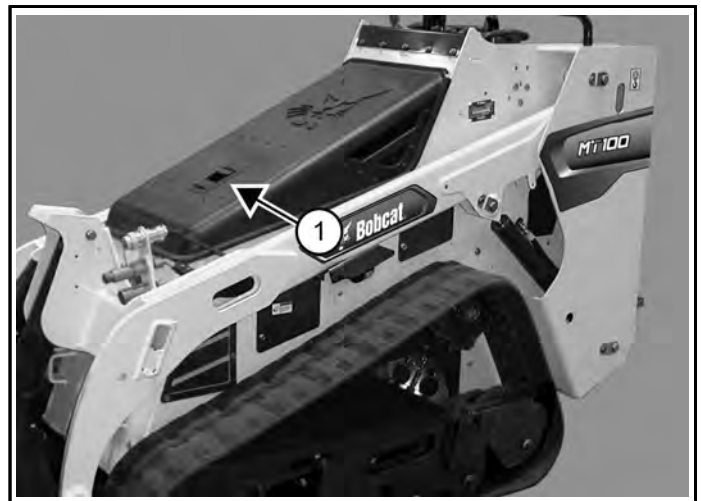
GENERAL HAZARD

Failure to follow instructions can cause serious injury or death. Never service or adjust the machine when the engine is running unless instructed to do so in the manual. ◀

W-2012

Raising

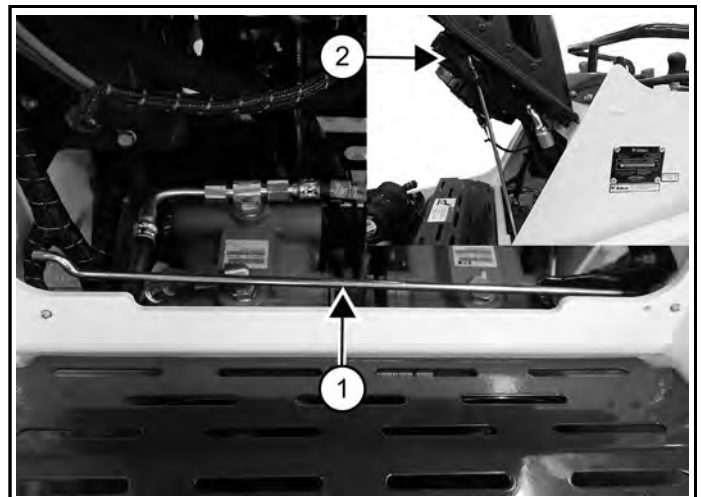
Figure 67



c201762c

1. Release the hood latch (Item 1) [Figure 67].
2. Raise and open the hood.

Figure 68



c205692a

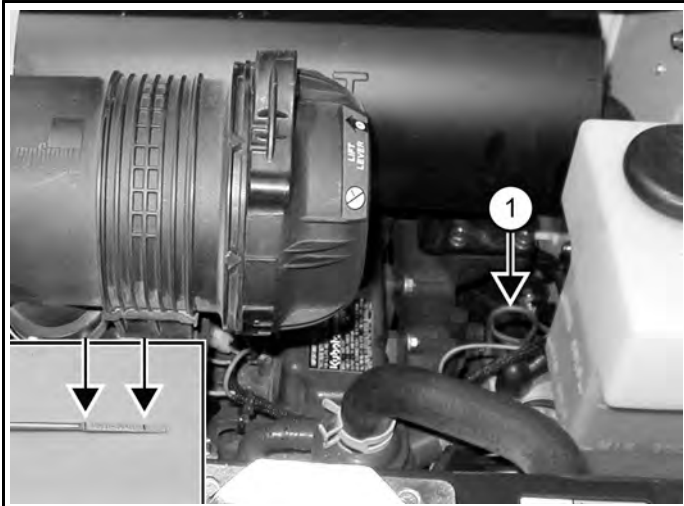
3. Lift the prop bar (Item 1) and insert into holding bracket (Item 2) [Figure 68] on left side of hood.

ENGINE LUBRICATION SYSTEM

Checking And Adding Engine Oil

Check the engine oil level every day before starting the engine for the work shift.

Figure 80



1. Open the hood and remove the dipstick (Item 1) [Figure 80].
2. Keep the oil level between the marks on the dipstick [Figure 80].
3. Install the dipstick and close the hood.

Engine Oil Chart

ENGINE CRANKCASE OIL	
Recommended SAE Viscosity Number	
Refer to the temperature range anticipated before next oil change.	
Must use API Category CK-4 or better or ACEA E9 or better.	
Do not use API category FA-4 engine oil.	
[1]	SAE 10W-30
[2]	SAE 15W-40

Bobcat engine oils are recommended for use in this machine. If Bobcat engine oil is not available, use a good quality engine oil that meets API Service Category of CK-4 or better, or ACEA E9 or better.

⚠ IMPORTANT

MACHINE DAMAGE HAZARD

Failure to follow directions may result in severe engine damage.

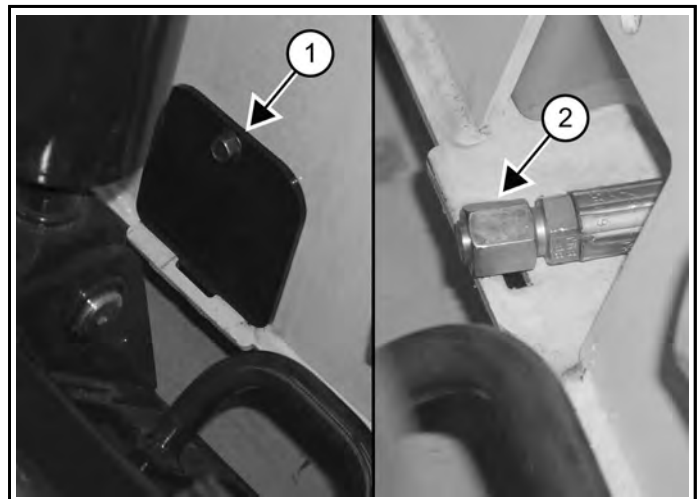
Use of API Service Category FA-4 engine oil is not approved and may cause irreversible damage to the engine. ◀

12384

Removing And Replacing Oil And Filter

For the service interval for replacing the engine oil and filter. (See Service Schedule on Page 54)

Figure 81



p-48520b

1. Remove the access cover (Item 1) [Figure 81] (located behind the tilt cylinder) and route the oil drain hose to a container at the front of the machine.
2. Remove the cap from the drain hose (Item 2) [Figure 81] and drain the oil. Dispose of the oil in an environmentally safe manner.
3. Install the cap on the drain hose and push the hose back into the machine.
4. Install the access cover.

⚠ WARNING

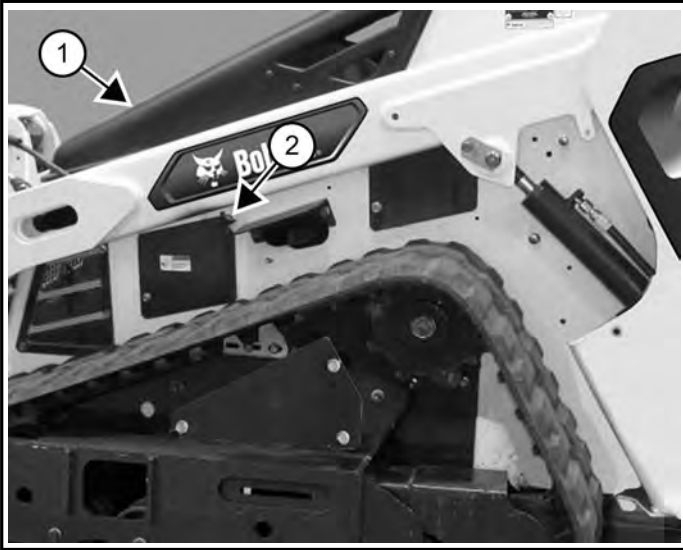
FIRE AND EXPLOSION HAZARD

Failure to use care around combustibles can cause serious injury or death.

Always clean up spilled flammable fluids or oil. Keep heat, flames, sparks, or lighted tobacco away from flammable fluids and oil. ◀

W-2103

Figure 82



C201718D

5. Open the hood (Item 1) [Figure 82].
6. Loosen the thumb screw (Item 2) [Figure 82].
7. Open the access cover on the left side of the machine.

Figure 83



p-89541c

8. Remove the oil filter (Item 3) [Figure 83] (located under the alternator) and clean the filter housing surface.
9. Put clean oil on the oil filter gasket. Install the filter and hand tighten.

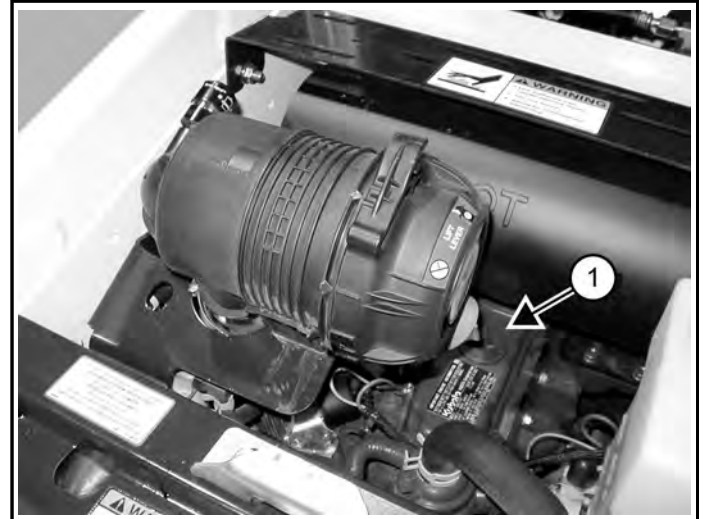
⚠ WARNING

GENERAL HAZARD

Failure to follow instructions can cause serious injury or death.
 Never service or adjust the machine when the engine is running unless instructed to do so in the manual. ◀

W2012

Figure 84



p-81833b

10. Remove the fill cap (Item 1) [Figure 84].
11. Put oil in the engine. (See Capacities on Page 103)
12. Install the fill cap.
13. Start the engine and let it run for several minutes.
14. Stop the engine and check for leaks at the oil filter.
15. Remove the dipstick and check the oil level.
16. Add oil as needed if the oil level is not at the top mark on the dipstick.
17. Install the dipstick and close the hood.
18. Close the side access cover.

⚠ WARNING

FIRE AND EXPLOSION HAZARD

Failure to use care around combustibles can cause serious injury or death.
 Always clean up spilled flammable fluids or oil. Keep heat, flames, sparks, or lighted tobacco away from flammable fluids and oil. ◀

W2103

Using A Booster Battery (Jump Starting)

⚠ WARNING

CHEMICAL HAZARD

Contact with or ingestion of battery acid can cause serious injury or death.

- Batteries contain acid that burns eyes and skin on contact. Wear safety goggles, protective clothing, and rubber gloves to keep acid off body.
- In case of acid contact, wash immediately with water. In case of eye contact, get prompt medical attention and wash eye with clean, cool water for at least 5 minutes.
- If electrolyte is ingested, drink large quantities of water or milk! DO NOT induce vomiting. Get prompt medical attention. ◀

W-2065

If it is necessary to use a booster battery to start the engine, be careful!

The booster battery must be 12 volt.

⚠ WARNING

EXPLOSION HAZARD

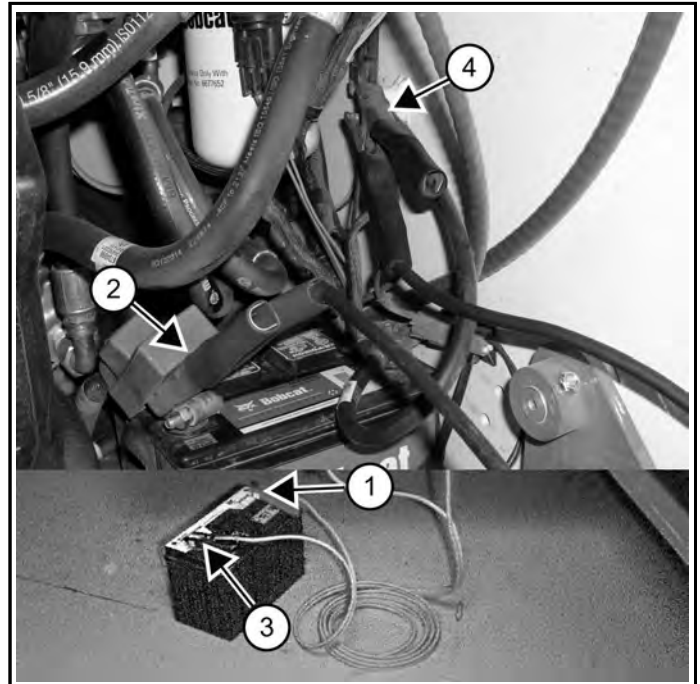
Battery gas can explode and cause serious injury or death.

- Keep arcs, sparks, flames and lighted tobacco away from batteries. When jumping from booster battery make final connection (negative) at machine frame.
- Do not jump start or charge a frozen or damaged battery. Warm battery to 16°C (60°F) before connecting to a charger. Unplug charger before connecting or disconnecting cables to a battery. Never lean over battery while boosting, testing or charging. ◀

W-2066

1. The key switch must be off when connecting jumper cables.
2. Open the rear door.

Figure 95



p124019b

3. Connect the end of the first cable (Item 1) [Figure 95] to the positive (+) terminal to the booster battery.
4. Connect the other end of the same cable (Item 2) [Figure 95] to the positive (+) terminal on the machine battery.
5. Connect the end of the second cable (Item 3) [Figure 95] to the negative (-) terminal of the booster battery.
6. Connect the other end of the same cable (Item 4) [Figure 95] to the machine frame.
7. Keep cables away from moving parts. Start the engine.
8. After the engine has started, remove the ground (-) cable (Item 4) [Figure 95] first.
9. Remove the cable from the positive terminal (Item 2) [Figure 95].
10. Remove the cables from the booster battery.
11. Close the rear door.

⚠ IMPORTANT

MACHINE DAMAGE HAZARD

Damage to the alternator can occur

Do not operate machine if:

- Engine is operated with battery cables disconnected.
- Battery cables are connected when using a fast charger or when welding on the machine. Remove both cables from the battery.
- Extra battery cables (booster cables) are connected wrong. ◀

I-2023

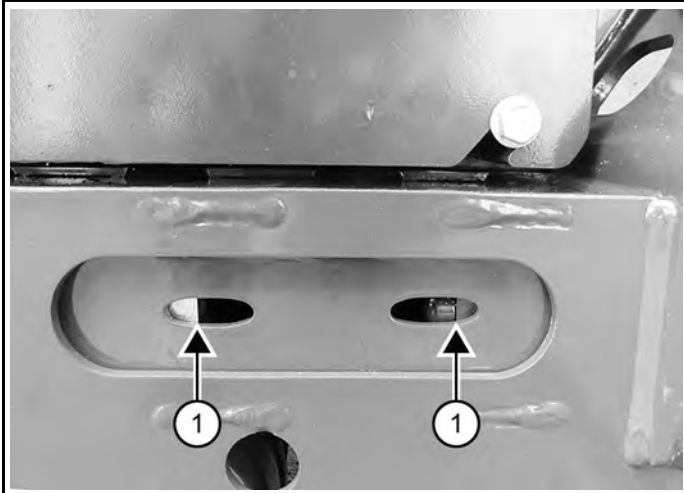
TRACK TENSION

Adjusting Track Tension

Track tension is important for good performance and to prevent the tracks from coming off.

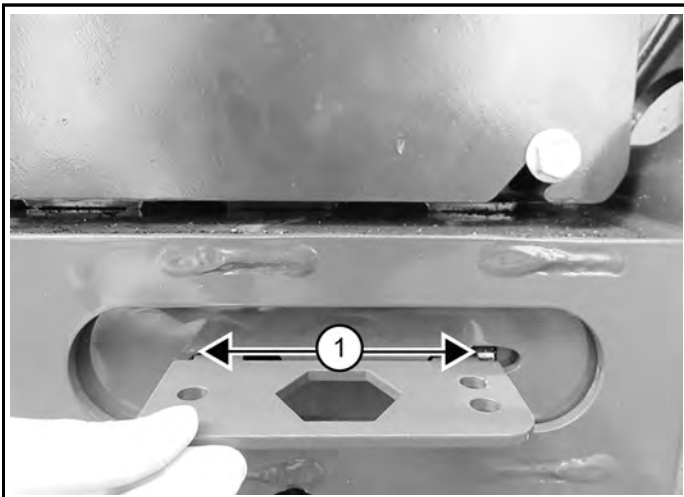
NOTE: The wear of track rollers vary with the working conditions and different types of soil conditions.

Figure 101



The track tension is measured between blocks (Item 1) [Figure 101].

Figure 102

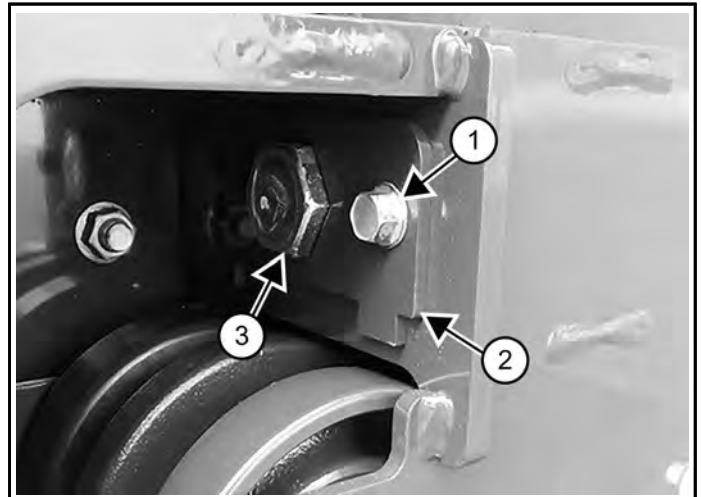


The tracks are adjusted correctly when the measurement between the blocks is 114 mm (4.50 in) (Item 1) [Figure 102].

NOTE: The retainer plate (Item 2) [Figure 103] has notches in the corners that are spaced at 114 mm (4.50 in) and is used for measuring the correct distance between the blocks. Adjust the track tension so the notched corners of the retainer plate fit snugly between the blocks (Item 1) [Figure 102].

1. Park the machine on a level surface.
2. Engage the parking brake.
3. Raise one side of the machine so that the track is about 50 mm (2 in) off the ground.
4. Lower the machine to jackstands, ensuring the jackstands do not touch the tracks.

Figure 103



5. Remove the locking bolt (Item 1) and retainer plate (Item 2) [Figure 103].
6. Turn the adjustment bolt (Item 3) [Figure 103]
 - a. Turn anticlockwise to tighten the track.
(Decrease the distance between the blocks [Figure 101].)
 - b. Turn clockwise to loosen the track.
(Increase the distance between the blocks [Figure 101].)
7. Turn until the correct measurement [Figure 102] is obtained and the nearest notch (Item 3) is aligned with the hole for the locking bolt (Item 1) [Figure 103].
8. Install the retainer plate (Item 2) and the locking bolt (Item 1) [Figure 103].

MACHINE LUBRICATION

Lubricating Grease Fittings

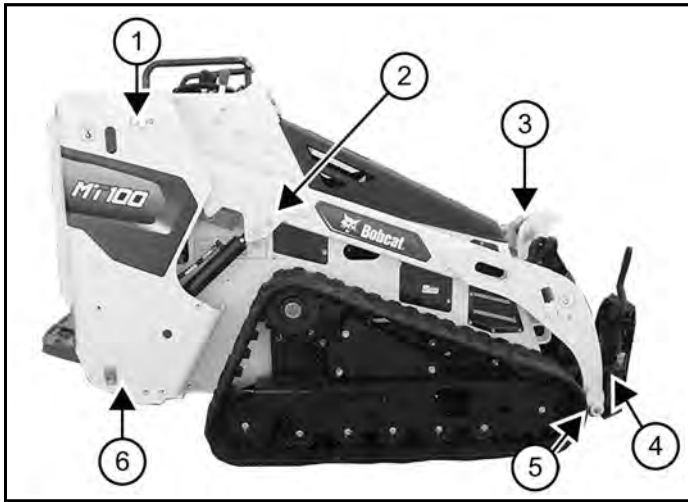
Lubricate the machine as specified for the best performance of the machine.
(See Service Schedule on Page 54)

Record the operating hours each time you lubricate the Bobcat machine.

Always use a good quality lithium-based multi-purpose grease. Apply lubricant until extra grease shows.

Lubricate the following locations:

Figure 112



C213202a

REF.	Location	No. of Fittings
1	Lift Arm Pivot	1 per side
2	Lift Cylinder Rod End	1 per side
3	Tilt Cylinder Base End	1
4	Bob-Tach Wedge (If equipped).	1 per side
5	Bob-Tach Pivot Pin (If equipped).	1 per side
6	Lift Cylinder Base End	1 per side

Figure 113

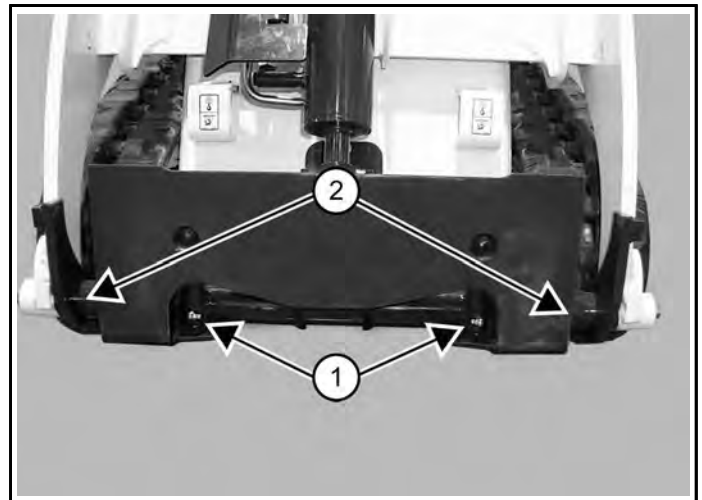


C213203a

REF.	Location	No. of Fittings
1	Tilt Cylinder Rod End	1

Common Industry Interface Lubrication

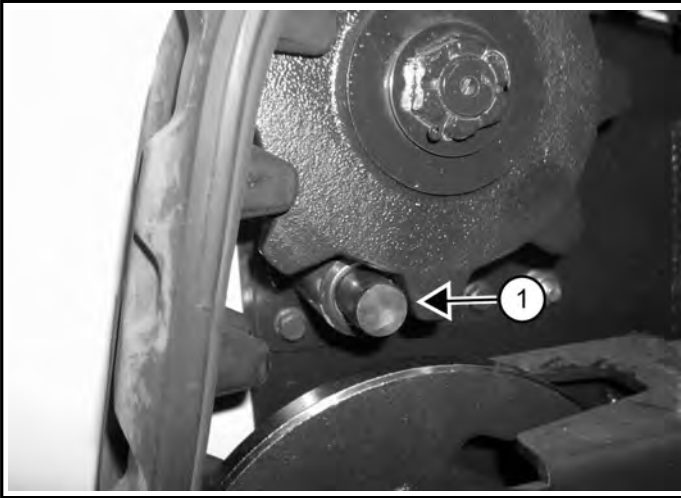
Figure 114



REF.	Location	No. of Fittings
1	Common Industry Interface Locking Pin (If equipped).	1 per side
2	Common Industry Interface Pivot Pin (If equipped).	1 per side

Parking Brake Lubrication

Figure 115



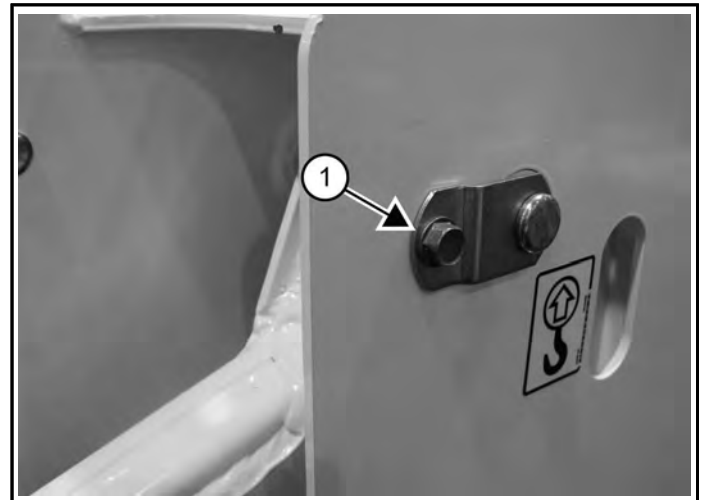
p48553a

1. Lubricate the parking brake pin (Item 1) [Figure 115] with anti-seize compound only every 250 hours.
2. Move the parking brake lever back and forth to spread the lubricant over the entire pin area.
3. Repeat the lubrication for the parking brake pin on the other side.

PIVOT PINS

Inspecting And Maintaining Pivot Pins

Figure 116



p124107a

1. All lift arm and cylinder pivots have a large pin held in position with a retainer and bolt (Item 1) [Figure 116].
2. Check that the bolts are tightened to 24 – 27 N·m (18 – 20 ft-lb) torque.

BOB-TACH SYSTEM (HAND LEVER)

Inspecting And Maintaining The Bob-Tach System

⚠ WARNING

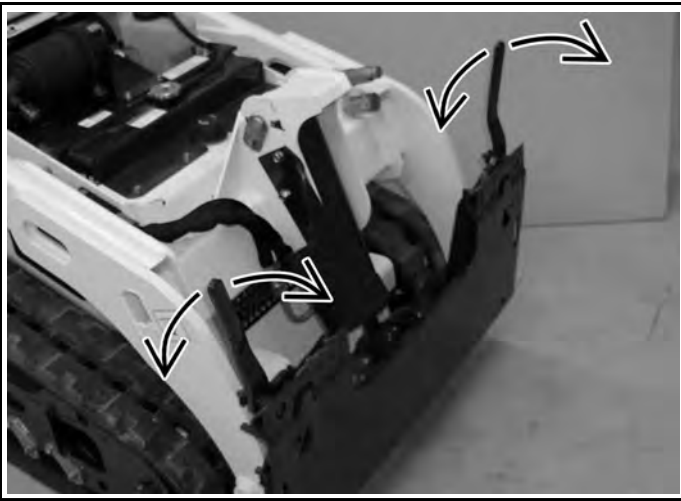
CRUSHING HAZARD

Failure to secure Bob-Tach wedges can allow attachment to come off and cause serious injury or death.

Both wedges must extend through the holes in the attachment mounting frame. Lever(s) must be fully down and locked.

W2102

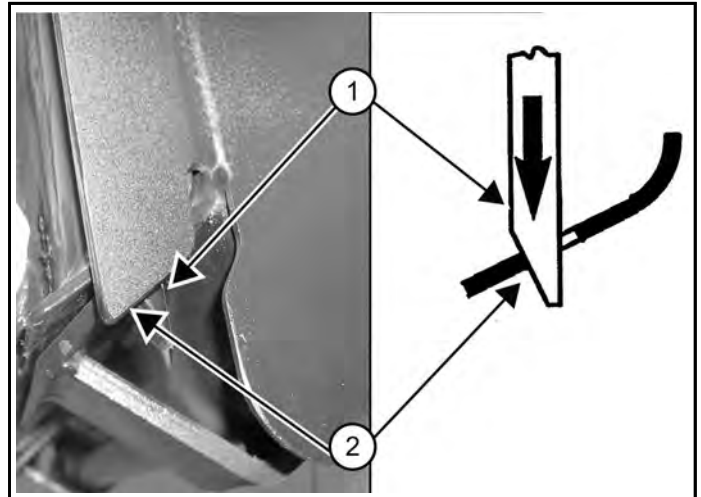
Figure 117



p-48412a

1. Move the Bob-Tach levers to engage and disengage the wedges [Figure 117]. The levers and wedges must move freely.

Figure 118



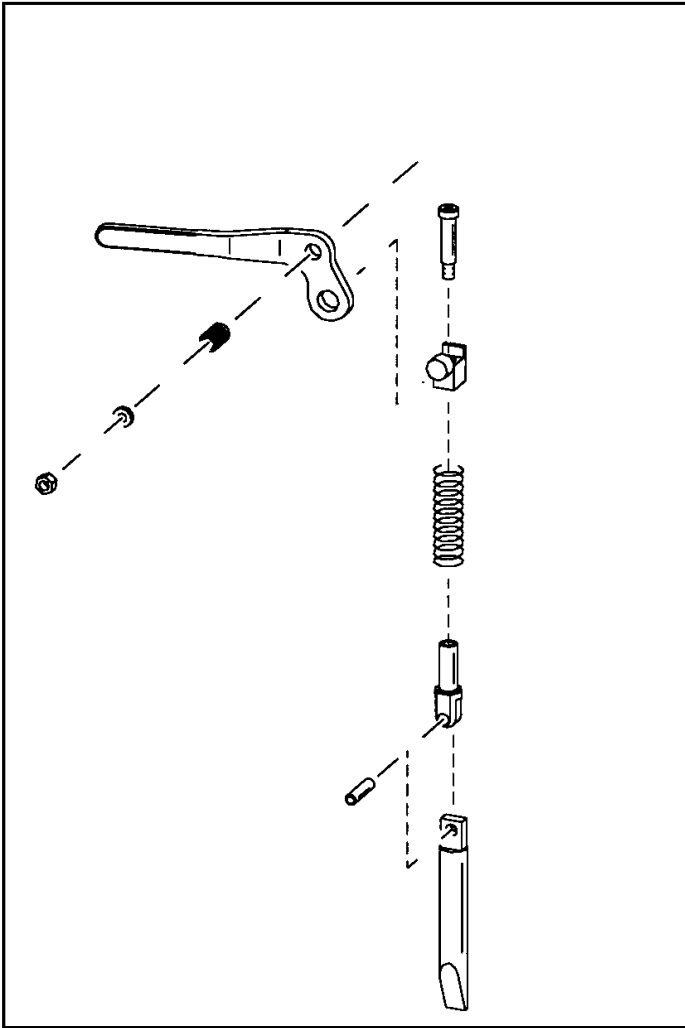
p-30904c

The wedges (Item 1) [Figure 118] must extend through the holes in the attachment mounting frame.

The spring loaded wedge must contact the lower edge of the hole in the attachment (Item 2) [Figure 118].

If the wedge does not contact the lower edge of the hole [Figure 118], the attachment will be loose and can come off the Bob-Tach attachment mounting system.

Figure 119



b-17460

2. Inspect the mounting frame on the attachment and the Bob-Tach attachment mounting system, linkages and wedges for excessive wear or damage [Figure 119].
3. Replace any parts that are damaged, bent, or missing.
4. Keep all fasteners tight.
5. Look for cracked welds.
Contact your Bobcat dealer for repair or replacement parts.
6. Lubricate the wedges.
(See Service Schedule on Page 54)
(See Machine Lubrication on Page 86)

COMMON INDUSTRY INTERFACE

Inspecting And Maintaining Common Industry Interface

⚠ WARNING

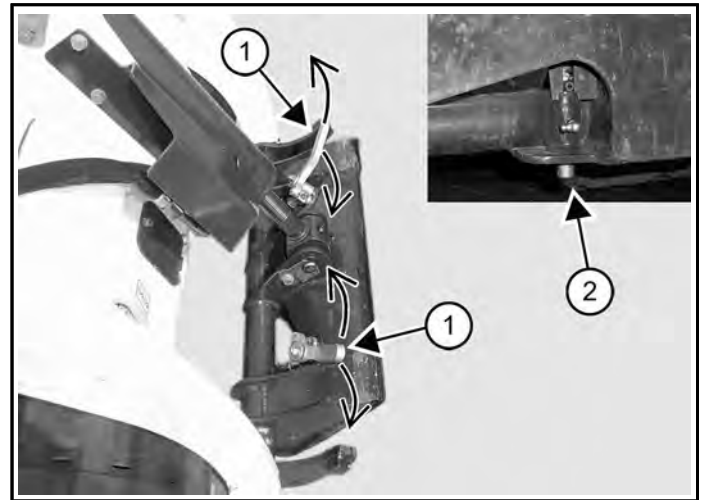
CRUSHING HAZARD

Failure to secure the locking pins can allow attachment to come off and cause serious injury or death.

- Both Common Industry Interface locking pins must extend through the holes in attachment frame.
- Lever must be fully down and locked. ◀

W-2998

Figure 120

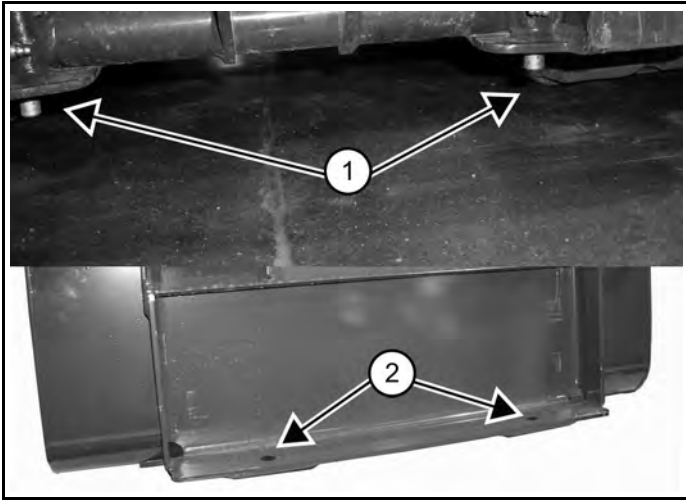


c205398a

1. Move the Common Industry Interface (CII) levers (Item 1) to engage and disengage the locking pins (Item 2) [Figure 120].

The levers and pins must move freely.

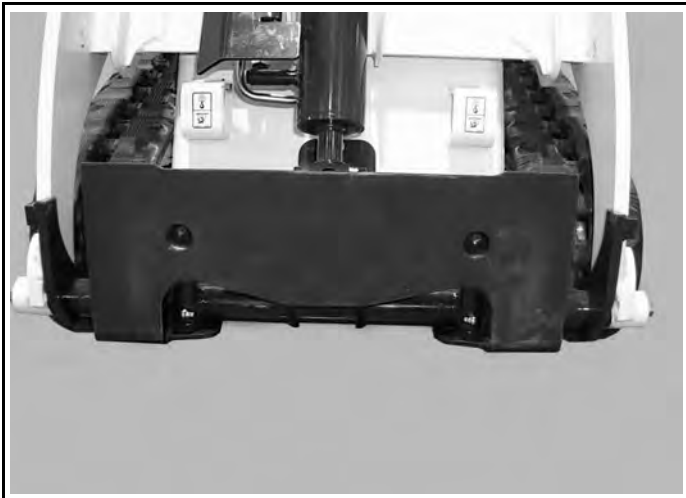
Figure 121



The pins (Item 1) must extend through the holes in the attachment mounting frame (Item 2) [Figure 121].

If the pin does not fully engage the attachment mounting frame hole [Figure 121], the attachment will be loose and can come off the interface.

Figure 122



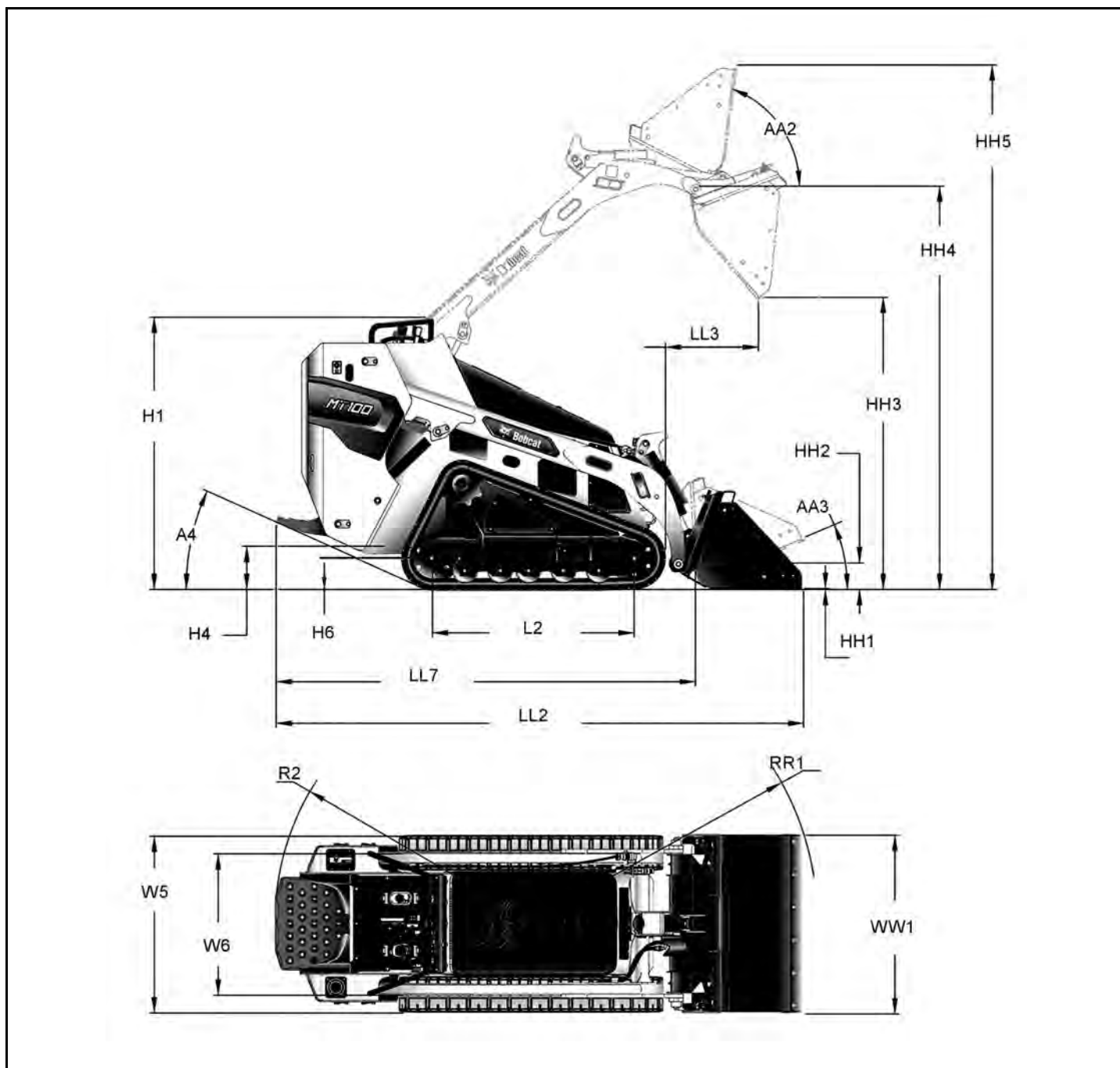
2. Inspect the mounting frame on the attachment and the Common Industry Interface, linkages, springs, and pins for excessive damage [Figure 122].
3. Replace any parts that are damaged, bent, or missing.
4. Keep all fasteners tight.
5. Look for cracked welds.

Contact your Bobcat dealer for repair or replacement parts.

6. Lubricate the pins.
(See Service Schedule on Page 54)
(See Machine Lubrication on Page 86)

DIMENSIONS (NARROW TRACK)

Figure 123



NA18547a

Certain specification(s) are based on engineering calculations and are not actual measurements. Specification(s) are provided for comparison purposes only and are subject to change without notice. Specification(s) for your individual Bobcat equipment will vary based on normal variations in design, manufacturing, operation conditions, and other factors.

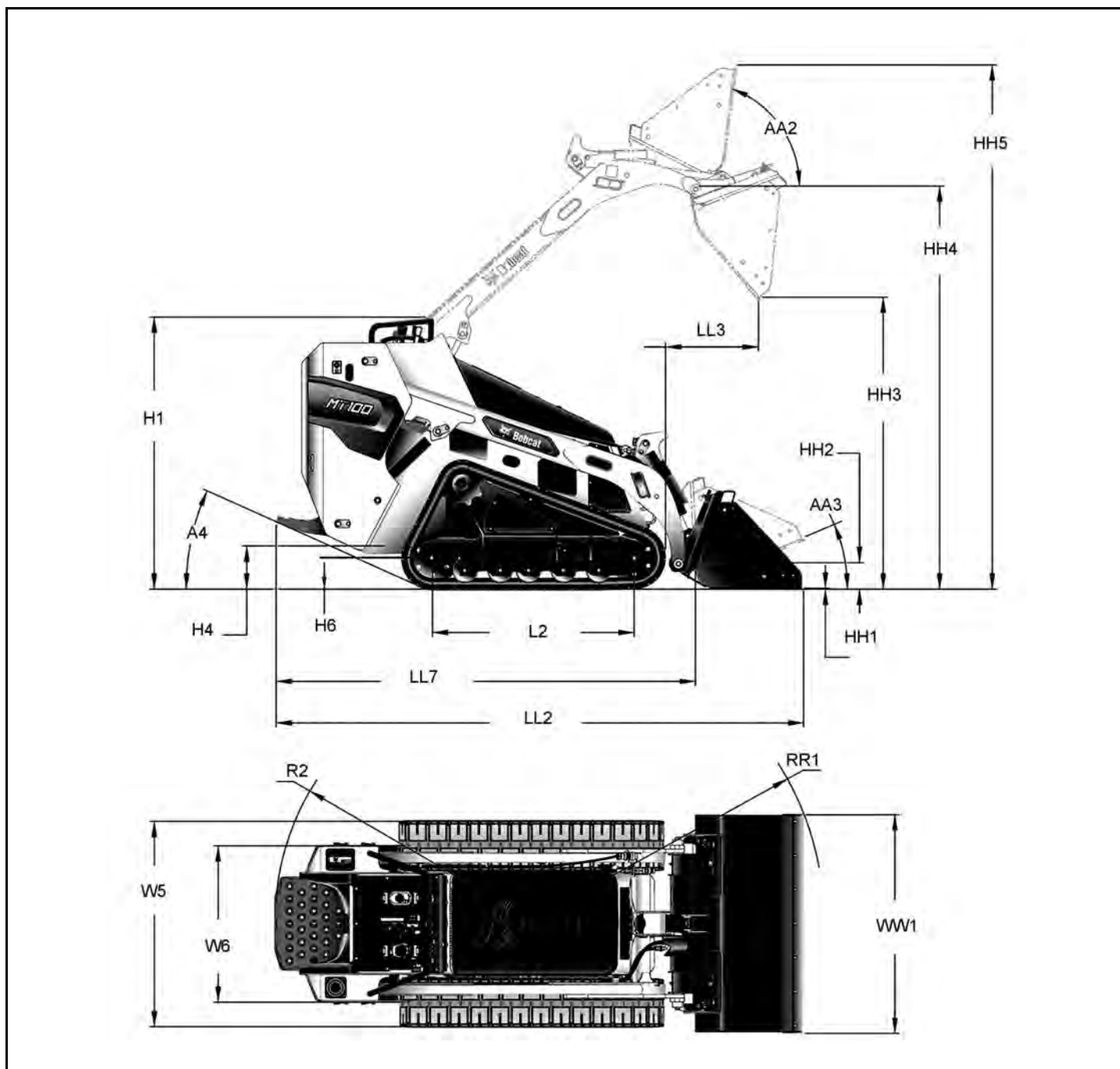
Where applicable, specifications conform to SAE or ISO standards and are subject to change without notice.

REF.	DESCRIPTION	WITH NARROW TRACK
AA2	MAXIMUM ROLLBACK – FULLY RAISED	83 degrees
HH5	OVERALL HEIGHT – FULLY RAISED	2677 mm (105.4 in)

REF.	DESCRIPTION	WITH NARROW TRACK
HH4	HEIGHT TO HINGE PIN – FULLY RAISED	2057 mm (81.0 in)
LL3	REACH – FULLY RAISED	475 mm (18.7 in)
HH3	DUMP HEIGHT AT 45° DUMP ANGLE	1510 mm (59.5 in)
HH2	CARRY POSITION HEIGHT	131 mm (5.2 in)
AA3	MAXIMUM ROLLBACK – AT GROUND	22.7 degrees
HH1	DIGGING DEPTH	2.1 mm (0.1 in) BELOW GRADE
LL2	OVERALL LENGTH	2698 mm (106.2 in)
LL7	LENGTH INCLUDING ATTACHMENT INTERFACE	2145 mm (84.5 in)
L2	CRAWLER BASE	1052 mm (41.4 in)
H6	CURBABILITY	182 mm (7.2 in)
H4	GROUND CLEARANCE	205 mm (8.1 in)
A4	ANGLE OF DEPARTURE	24 degrees
H1	OVERALL HEIGHT	1387 mm (54.6 in)
RR1	MACHINE CLEARANCE RADIUS	1455 mm (57.3 in)
WW1	BUCKET WIDTH	914 mm (36.0 in)
W6	WIDTH ACROSS AXLE FLANGES W/O STUDS	878 mm (34.6 in)
W5	WIDTH ACROSS MACHINE WITHOUT TRACKS	894 mm (35.2 in)
R2	REAR OF MACHINE CLEARANCE RADIUS	1324 mm (52.1 in)

DIMENSIONS (WIDE TRACK)

Figure 124



NA18548a

REF.	DESCRIPTION	WITH WIDE TRACK
AA2	MAXIMUM ROLLBACK – FULLY RAISED	83 degrees
HH5	OVERALL HEIGHT – FULLY RAISED	2677 mm (105.4 in)
HH4	HEIGHT TO HINGE PIN – FULLY RAISED	2057 mm (81.0 in)
LL3	REACH – FULLY RAISED	475 mm (18.7 in)
HH3	DUMP HEIGHT AT 45° DUMP ANGLE	1510 mm (59.5 in)

REF.	DESCRIPTION	WITH WIDE TRACK
HH2	CARRY POSITION HEIGHT	131 mm (5.2 in)
AA3	MAXIMUM ROLLBACK – AT GROUND	23 degrees
HH1	DIGGING DEPTH	2 mm (0.1 in) BELOW GRADE
LL2	OVERALL LENGTH	2698 mm (106.2 in)
LL7	LENGTH INCLUDING ATTACHMENT INTERFACE	2145 mm (84.5 in)
L2	CRAWLER BASE	1052 mm (41.4 in)
H6	CURBABILITY	182 mm (7.2 in)
H4	GROUND CLEARANCE	205 mm (8.1 in)
A4	ANGLE OF DEPARTURE	23.8 degrees
H1	OVERALL HEIGHT	1387 mm (54.6 in)
RR1	MACHINE CLEARANCE RADIUS	1490 mm (58.7 in)
WW1	BUCKET WIDTH	1118 mm (44.0 in)
W6	WIDTH ACROSS AXLE FLANGES W/O STUDS	1019 mm (40.1 in)
W5	WIDTH ACROSS MACHINE WITHOUT TRACKS	1035 mm (40.8 in)
R2	REAR OF MACHINE CLEARANCE RADIUS	1324 mm (52.1 in)

PERFORMANCE

	With Standard Narrow Tracks and Bucket	With Optional Wide Tracks and Bucket
Rated Operating Capacity	453 kg (1000 lb) (With the factory installed counterweights installed on the track frame)	476 kg (1050 lb) (With the factory installed counterweights installed on the track frame)
Tipping Load	1314 kg (2898 lb)	1375 kg (3032 lb)
Operating Weight	1538 kg (3390 lb)	1611 kg (3552 lb)
Breakout Force – Lift	1510 kg (3330 lb)	1572 kg (3466 lb)
Breakout Force – Tilt	1179 kg (2599 lb)	1215 kg (2679 lb)
Travel Speed		
Forward	0 – 6,6 km/h (0 – 4.1 mph)	0 – 6,6 km/h (0 – 4.1 mph)
Reverse	0 – 4,7 km/h (0 – 2.9 mph)	0 – 4,7 km/h (0 – 2.9 mph)

SPECIFICATION BUCKET SPECIFICATIONS

Weight	76 kg (168 lb)
Heap Capacity	0,13 m ³ (4.7 ft ³)
Struck Capacity	0,10 m ³ (3.7 ft ³)
Make	Dirt Bucket, 0.9 m (36 in) wide

CAPACITIES

Fuel	26,5 L (7 U.S. gal)
Engine Lubrication and Filter	3,6 L (3.8 qt)
Engine Cooling System	4,3 L (4.5 qt)
Hydraulic / Hydrostatic Reservoir Only (Centre of Sight Glass)	9,5 L (2.5 U.S. gal)
Hydraulic / Hydrostatic System	20,0 L (5.3 U.S. gal)

TRACKS

Standard	180 mm (7.1 in) Rubber
Wide (Optional)	250 mm (9.8 in) Rubber

GROUND PRESSURE

Standard Track And 36" Bucket	36,3 kPa (0.363 bar) (5.3 psi)
Wide Track And 44" Bucket	27,0 kPa (0.270 bar) (4.0 psi)

TEMPERATURE RANGE

Operation and storage	-17° – +43°C (-1.4° – +110°F)
-----------------------	-------------------------------

A			
accessories	10	operating instructions	27
adjusting the drive belt tension		controls	
drive belt	84	controls	27
adjusting track tension		specifications	97
track tension	82	coolant	
alternator belt replacement		type	72
alternator belt	83	counterweight	40
attachment control device	34	counterweight positions	
attachments	10	counterweights	40
Bob-Tach system compatible	10	counterweights	
choosing the correct bucket	41	counterweight positions	40
Common Industry Interface compatible	10	effect on the machine and operation	40
installing the attachment Bob-Tach system	42	main frame upright mounted counterweight	40
installing the attachment Common Industry		track frame mounted counterweight	40
Interface	44		
pallet fork	42	D	
removing the attachment Bob-Tach system	43	daily inspection and maintenance	35
removing the attachment Common Industry		declaration of conformity	5–6
Interface	45	delivery report	8
auxiliary hydraulic control		description	
continuous flow	32	drive belt	84
auxiliary hydraulic control,		electrical system	74
variable flow	32	track roller and idler lubrication	85
		diesel fuel	
B		safety	15
basic operating instructions		drive system	
operating procedure	46	specifications	102
battery		driving and steering the machine	30
charging	76	operating instructions	30
during machine storage	76	driving on rough terrain and over kerbs	
maintainer	76	operating procedure	46
maintaining charge level	76	driving with auger installed	
maintenance	75	operating procedure	47
testing	76		
before operation	12	E	
belt adjustment		effect on the machine and operations	
alternator belt	83	counterweights	40
biodiesel blend fuel	67	electrical	
Bob-Tach system compatible		specifications	101
attachments	10	electrical system	
		battery maintenance	75
C		engine	
capacities		specifications	99
specifications	103	engine oil	
checking and adding engine oil		chart	70
engine lubrication system	70	engine serial number	8
checking and adding hydraulic fluid		engine speed	28
hydraulic / hydrostatic system	79	engine speed control	
checking level		operating instructions	28
engine cooling system	72	ethylene glycol	72
choosing the correct bucket			
attachments	41	F	
cleaning		fastening	
engine cooling system	72	transporting machine	50
cleaning procedure		features	
spark arrester muffler	81	options and accessories	10
cold temperature		standard items	10
starting the engine	38	filling the fuel tank	
Common Industry Interface compatible		fuel system	67
attachments	10	fire prevention	
continuous flow		electrical	14
auxiliary hydraulic control	32	fire extinguishers	15
control	27	hydraulic system	14
control identification		flammable fluids	14

fuel cleanliness level.....	67		
fuel filter			
fuel system.....	68		
fuel specifications.....	67		
fuel standards (EU).....	67		
fuel standards (NA).....	67		
fuelling			
diesel.....	15		
fuse and relay identification			
electrical system.....	74		
fuse and relay location			
electrical system.....	74		
G			
grinding safety.....	15		
ground pressure			
specifications.....	105		
H			
hydraulic fluid			
chart.....	79		
hydraulic reservoir breather			
hydraulic / hydrostatic system.....	80		
hydraulic system			
specifications.....	100		
I			
inspecting and maintaining			
Bob-Tach system.....	88		
Common Industry Interface.....	89		
inspecting and maintaining pivot pins			
pivot pins.....	87		
inspecting auxiliary hydraulic interlock			
neutral start interlock.....	60		
inspecting lift and tilt function lockouts			
preventive maintenance.....	59		
inspecting lift arm bypass control			
preventive maintenance.....	58		
inspecting the continuous flow shutoff pedal			
auxiliary hydraulic control system.....	61		
inspecting traction drive interlocks			
neutral start interlock.....	60		
inspection checklist.....	58		
installing			
lift arm support.....	62		
installing the attachment Bob-Tach system			
attachments.....	42		
installing the attachment Common Industry Interface			
attachments.....	44		
intended use.....	26		
introduction.....	7		
ISO 9001			
certification.....	7		
BSI.....	7		
CE.....	7		
ISO 9001.....	7		
TUV.....	7		
K			
key switch			
starting the engine.....	37		
L			
lift / tilt joystick.....	31		
lift arm bypass.....	28		
lift arm bypass control			
operating instructions.....	28		
lifting the machine.....	49		
loading and unloading			
transporting machine.....	50		
lubricating grease fitting			
lubricating the machine.....	86		
M			
machine identification.....	9		
machine serial number.....	8		
machine signs			
pictorial only safety signs.....	16		
machine storage.....	76		
main frame upright mounted counterweight			
counterweights.....	40		
maintenance intervals.....	54		
maintenance safety.....	14		
N			
narrow track dimensions			
specifications.....	92		
O			
oil			
engine.....	70		
opening and closing			
rear door.....	64		
operating instructions			
control identification.....	27		
operating procedure			
basic operating instructions.....	46		
driving on rough terrain and over kerbs.....	46		
driving with auger installed.....	47		
operating with a full bucket.....	48		
operating with an empty bucket.....	48		
operating with a full bucket			
operating procedure.....	48		
operating with an empty bucket			
operating procedure.....	48		
operator position.....	30		
options.....	10		
P			
pallet fork			
attachments.....	42		
parking brake.....	29		
operating instructions.....	29		
parking brake lubrication			
lubricating the machine.....	87		
performance			
specifications.....	96		
pre-starting			
procedure.....	36		
pre-starting procedure.....	36		
preventative maintenance			
hydraulic / hydrostatic system.....	80		
preventive maintenance			
air cleaner service.....	65–66		

- ~~alternator belt~~ 83
 auxiliary hydraulic control system 61
 Bob-Tach system 88
 Common Industry Interface 89
~~drive belt~~ 84
 electrical system 74, 77–78
~~engine cooling system~~ 72–74
 engine lubrication 70
 engine lubrication system 70
 fuel system 67–68
 hood 64
~~hydraulic / hydrostatic system~~ 79–80
 inspecting lift and tilt function lockouts 59
 inspecting lift arm bypass control 58
 lift arm support 62–63
 lubricating the machine 86–87
 neutral start interlock 60
 pivot pins 87
 raising and lowering the hood 63
 rear door 64–65
 spark arrester muffler 81
~~track roller and idler lubrication~~ 85
~~track tension~~ 82
 procedure
 ~~stopping the engine and leaving the machine~~ 39
 ~~towing the machine~~ 49
 propylene glycol 72
 publications and training resources 16
- R**
- raising and lowering the hood
 preventive maintenance 63
 rated operating capacity
 buckets 41
 calculating 41
 description 41
~~rear door bumper adjustment~~
~~rear door~~ 65
 removing
 lift arm support 63
~~removing air from the fuel system~~
 fuel system 68
~~removing and installing the battery~~
 electrical system 78
~~removing and replacing hydraulic / hydrostatic filter~~
 hydraulic / hydrostatic system 79
~~removing and replacing hydraulic fluid~~
 hydraulic / hydrostatic system 80
~~removing and replacing oil and filter~~
 engine lubrication system 70
 removing the attachment Bob–Tach system
 attachments 43
 removing the attachment Common Industry Interface
 attachments 45
~~removing the coolant~~
 engine cooling system 73
~~removing water from fuel filter~~
 fuel system 68
~~replacing element~~
 fuel system 68
~~replacing the coolant~~
 engine cooling system 74
~~replacing the filter elements~~
 air cleaner service 65
 preventive maintenance
 air cleaner service 65
~~replacing the inner filter~~
- air cleaner service 66
 replacing the outer filter
 air cleaner service 65
- S**
- safety instructions
 before operation 12
~~serial number~~
 location 8
 service schedule 54
 spark arrester exhaust system safety 15
 specification bucket specifications
 specifications 98
 specifications
 capacities 103
 controls 97
 drive system 102
~~electrical~~ 101
 engine 99
 ground pressure 105
~~hydraulic system~~ 100
 narrow track dimensions 92
 performance 96
 specification bucket specifications 98
 temperature range 107
~~torque for general metric bolts~~ 108
~~torque for general sae bolts~~ 108
 wide track dimensions 94
 starting safety 15
 starting the engine
 cold temperature 38
 key switch 37
 warming the hydraulic / hydrostatic system 38
 stopping the engine and leaving the machine
 procedure 39
 stopping the machine 31
~~storage~~
 and return to service 91
 preparing for 91
 striker adjustment
 hood 64
- T**
- ~~towing the machine~~
 procedure 49
~~track frame mounted counterweight~~
 counterweights 40
- U**
- ultra low sulfur fuel 67
 using a booster battery
 electrical system 77
 using the drive / steering control to stop the machine
 operating instructions 31
- V**
- variable flow
 auxiliary hydraulic control 32
- W**
- warming the hydraulic / hydrostatic system

starting the engine 38
warranty
 machine 110
welding safety 15
wide track dimensions
 specifications 94

